

the

is

he

see

here

me

I

they

of

can

for

on

my

have

do

like

in

no

you

said

a

was

to

this

it

play

and

she

go

at

am

are

the

Day 2

Name: _____

Trace the word and say it aloud:

the the the



The sun is in the sky

Write the word:

Cut out the letters at the bottom of the page and mix them up. Then paste them in the right squares to finish the sentence:

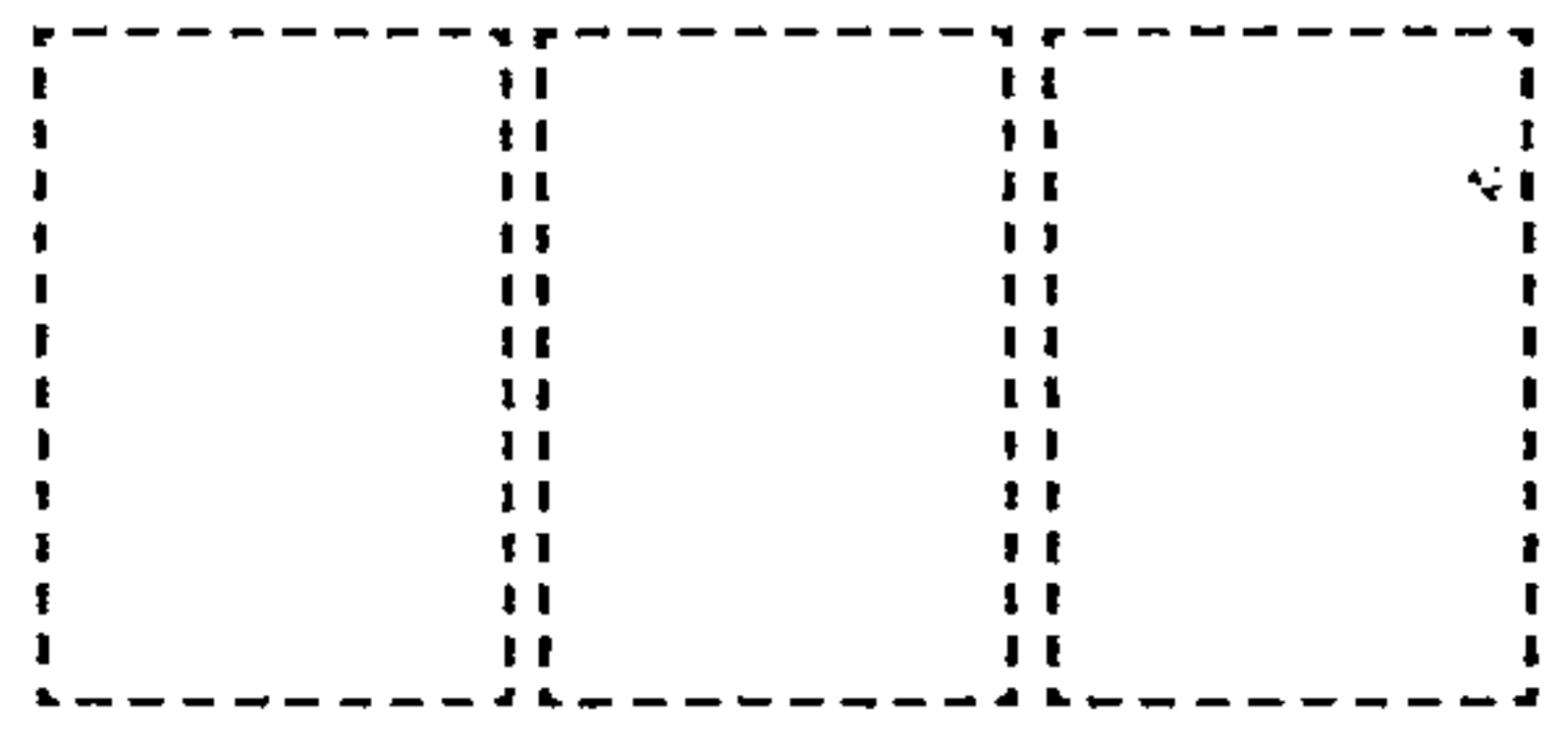

sun is in the sky.

Write the word to finish the sentence:

_____ sun is in the sky.



Write your own sentence using the word:

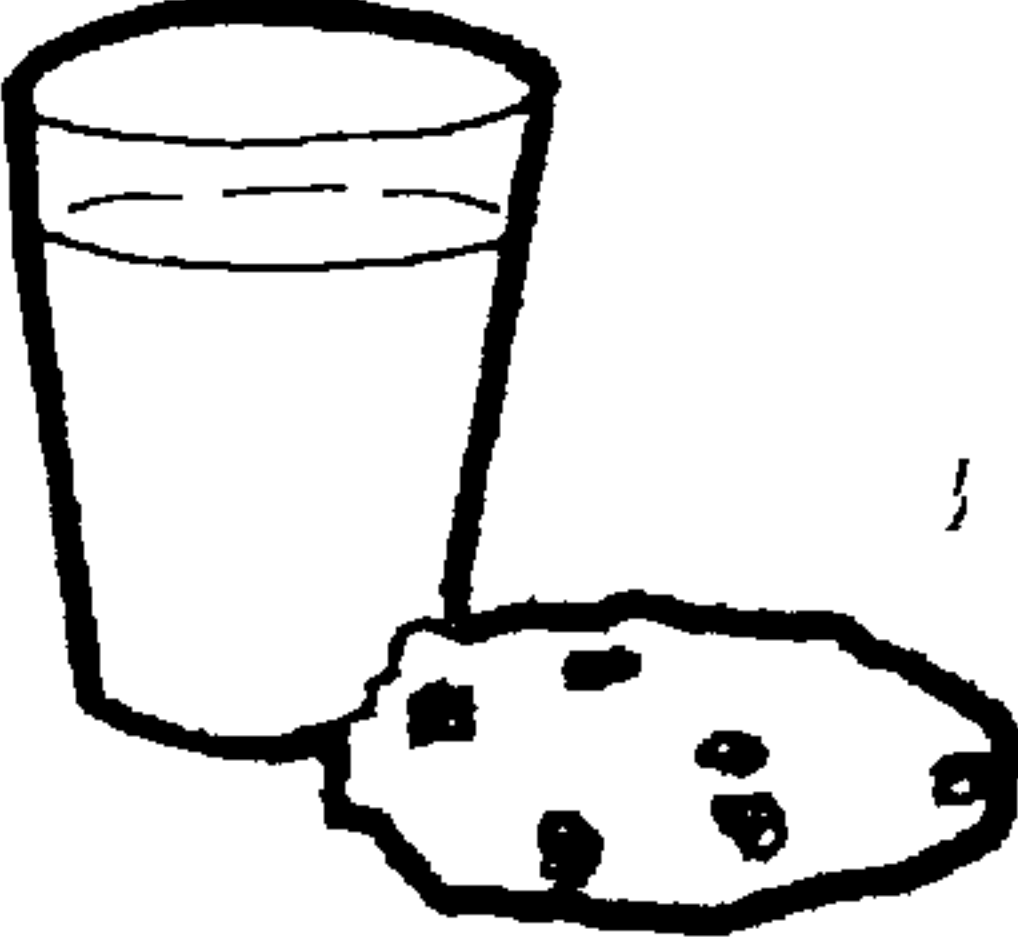
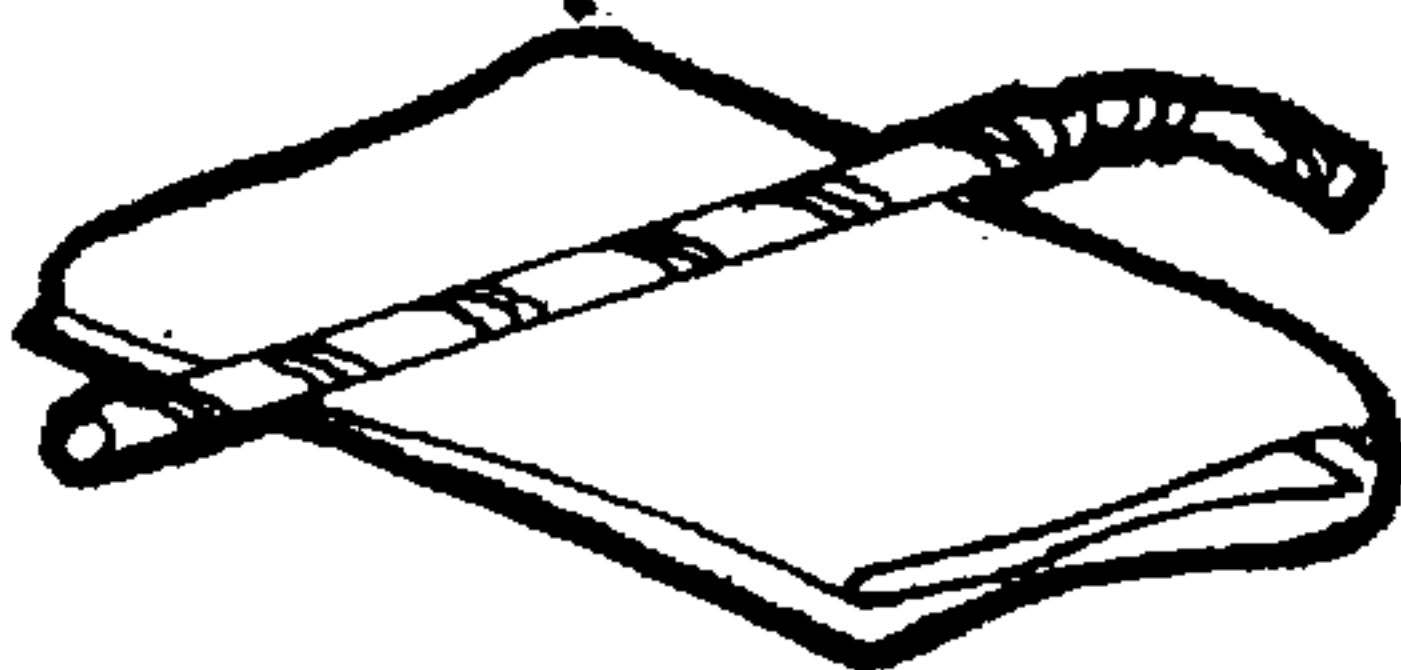
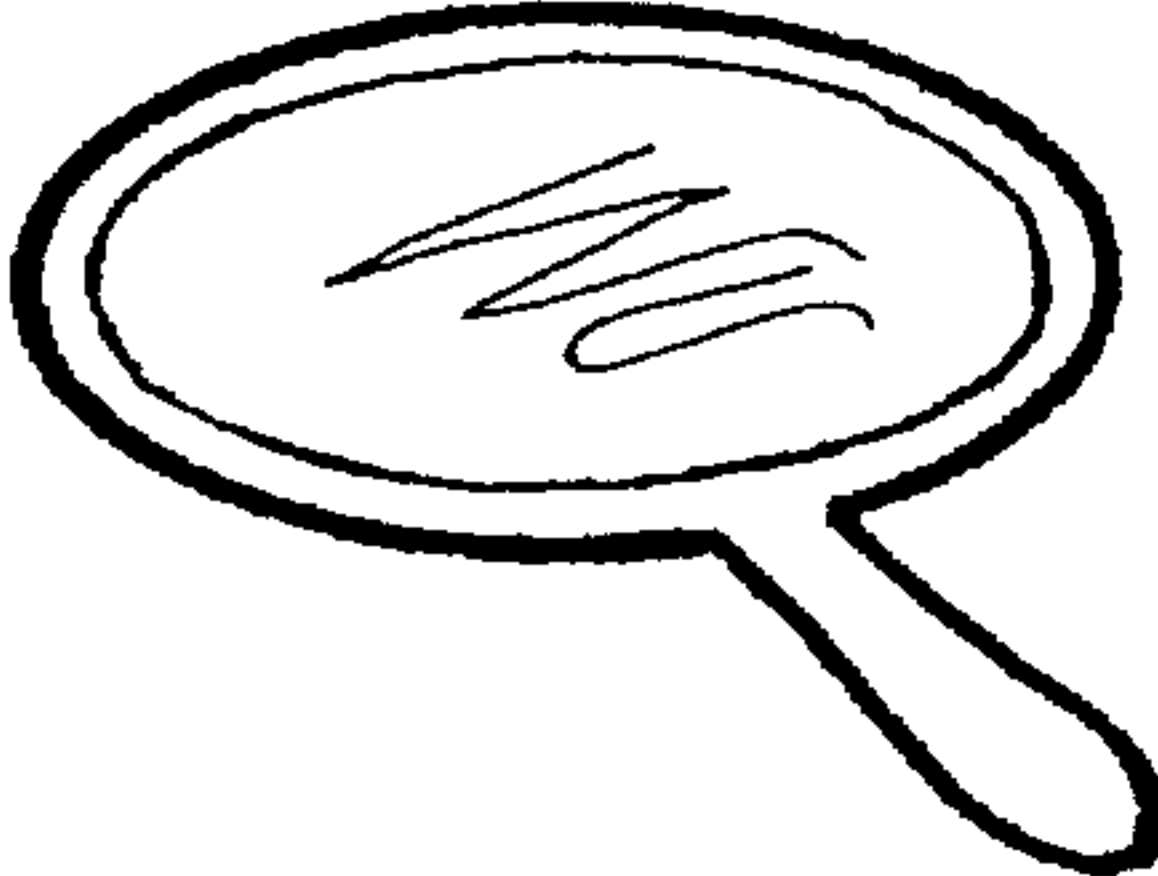
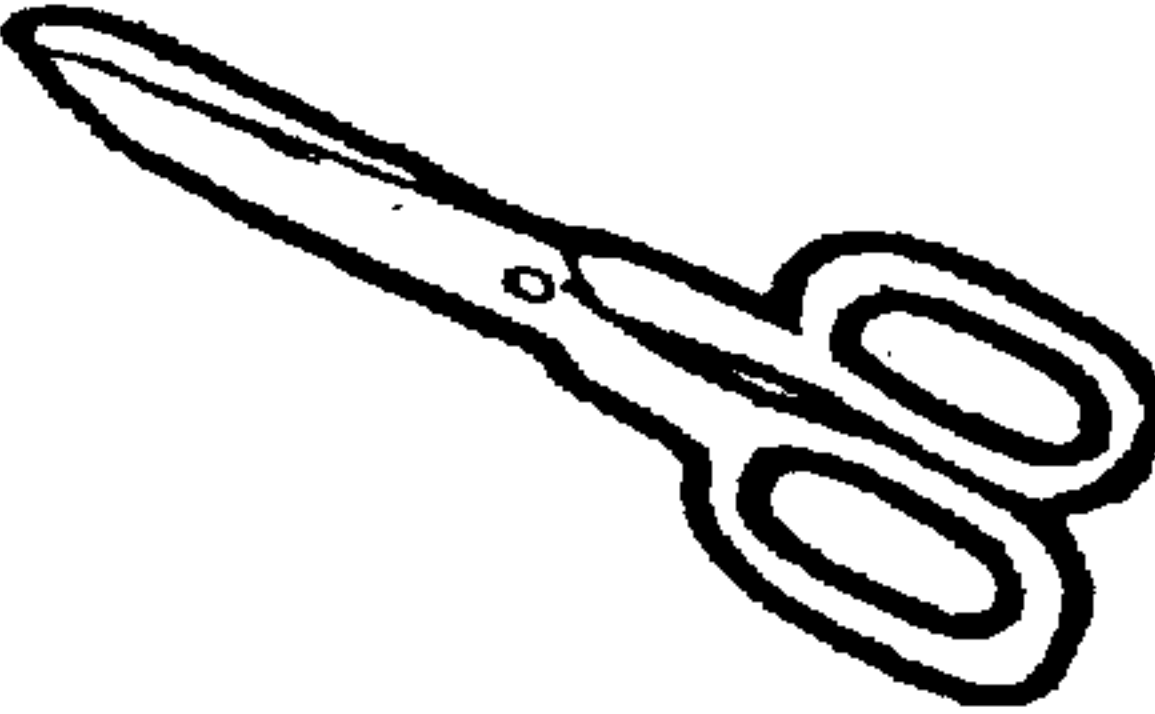
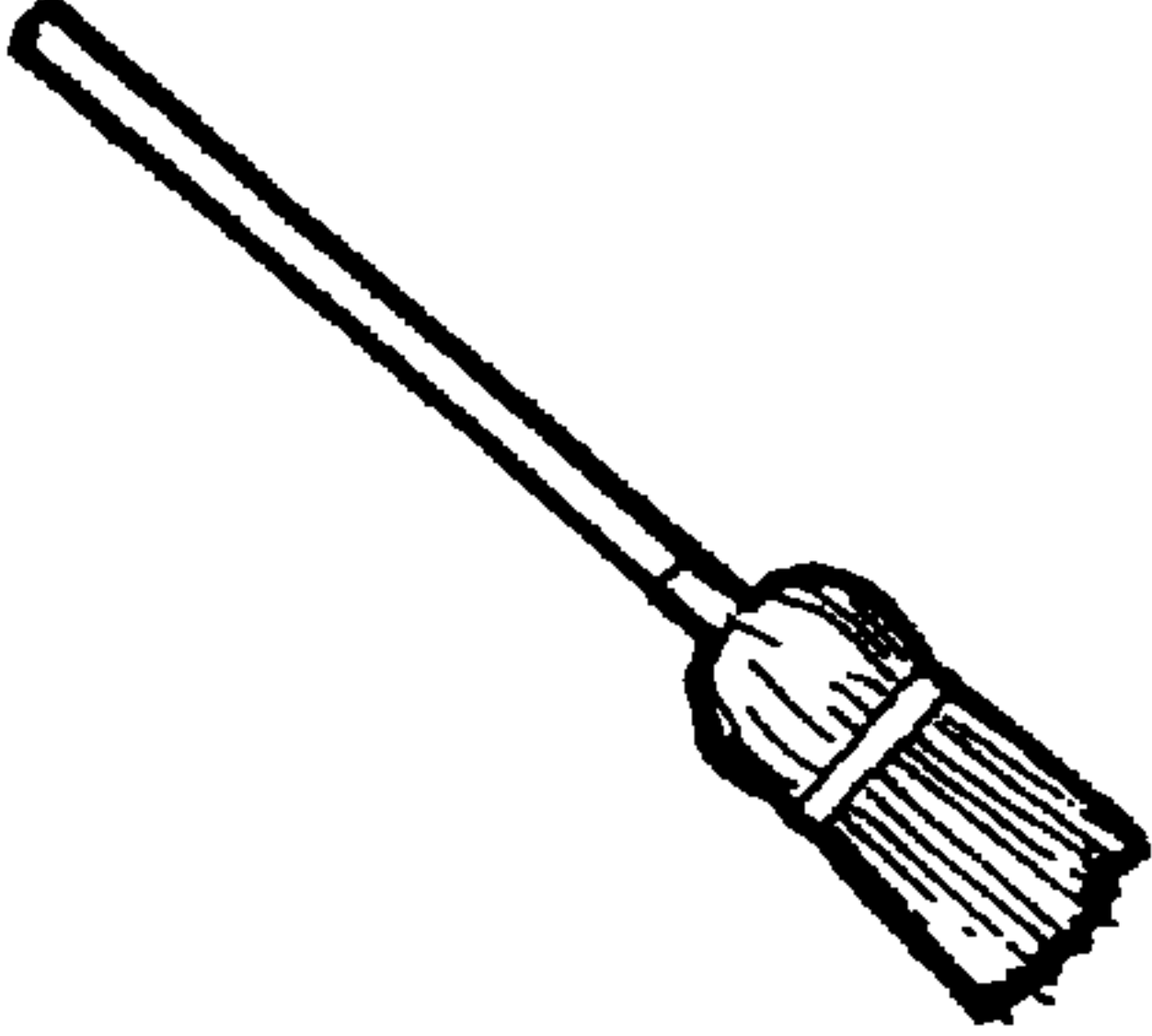

Story Summary Sentence Strips

<p>The boy gave the mouse a cookie, and the mouse asked for a glass of milk.</p>	
<p>The mouse asked for a straw and a napkin.</p>	
<p>The mouse wanted to look in a mirror.</p>	
<p>The mouse asked for a pair of scissors to trim his hair.</p>	
<p>The mouse asked for a broom to clean up.</p>	

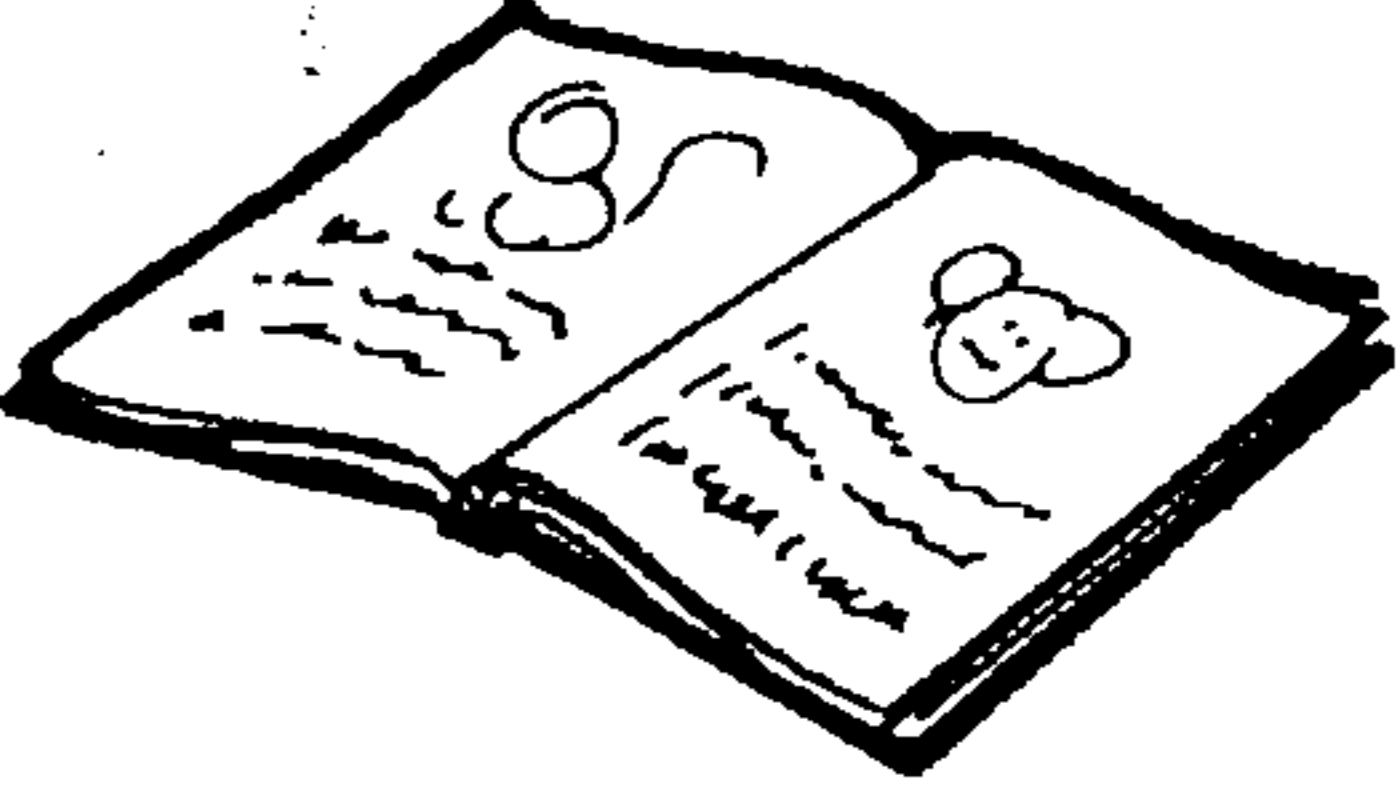
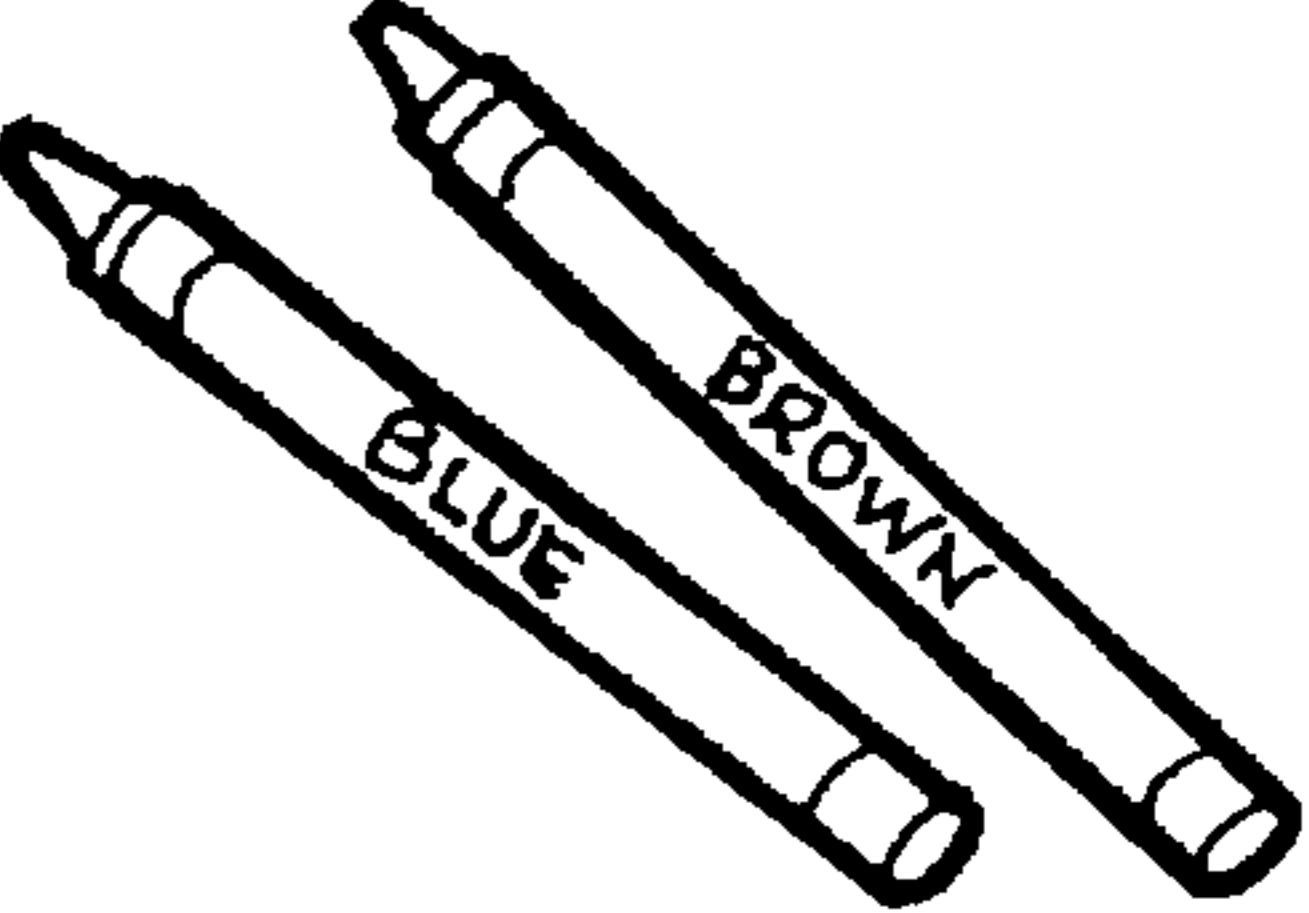
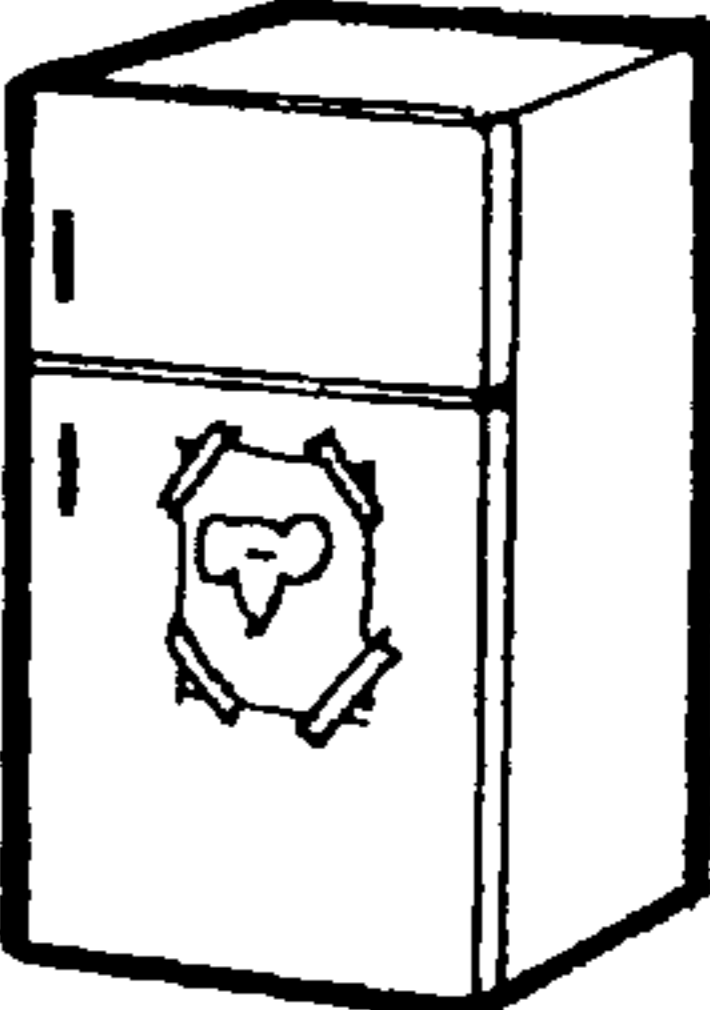
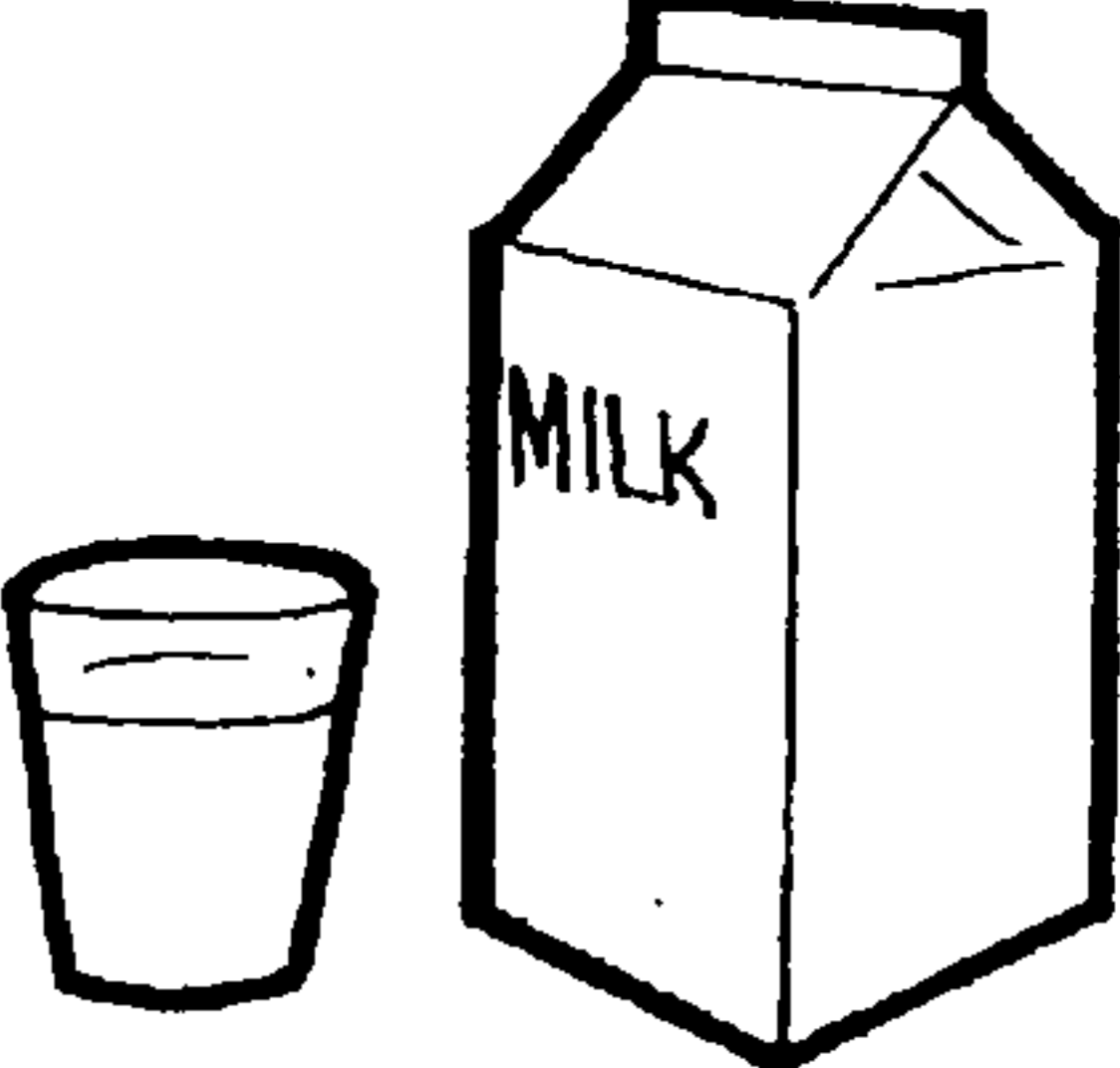
Story Summary Sentence Strips *(cont.)*

<p>The mouse started to take a nap, and the boy read him a story.</p>	
<p>The mouse asked for some paper and crayons.</p>	
<p>The mouse wanted to hang his picture on the refrigerator.</p>	
<p>The mouse became thirsty and asked for a glass of milk.</p>	
<p>And chances are if he asks for a glass of milk, he'll want a cookie to go with it!</p>	

see

Name: _____

Trace the word and say it aloud:

see see see



My glasses help me see.

Write the word:

Cut out the letters at the bottom of the page and mix them up. Then paste them in the right squares to finish the sentence:

My glasses help me

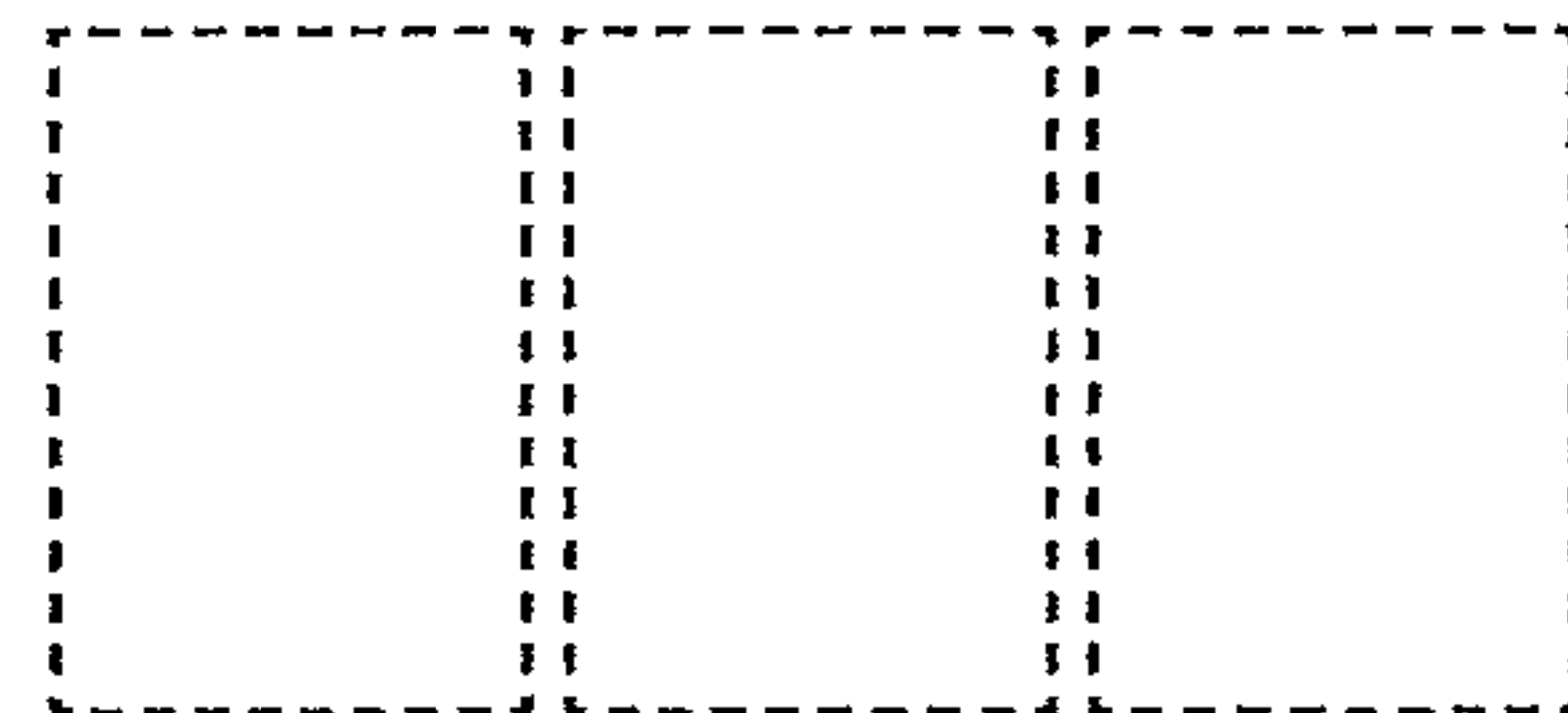

Write the word to finish the sentence:

My glasses help me _____

Write your own sentence using the word:

s e e

Name _____

Story-Go-Round

Directions: Color the pictures in circle A. Cut out the circle.



Circle A

Name _____

Story-Go-Round *(cont.)*

Directions: Write your name on circle B. Trace over the story letters with a crayon. Color the entire circle. Cut out the circle and Space #1. Hold circles A and B together with circle B on top. Insert a paper fastener through the center holes. Turn the Story-Go-Round and tell the story as you turn!



Name: _____

Color the pattern in each row. Color the picture that completes the pattern.

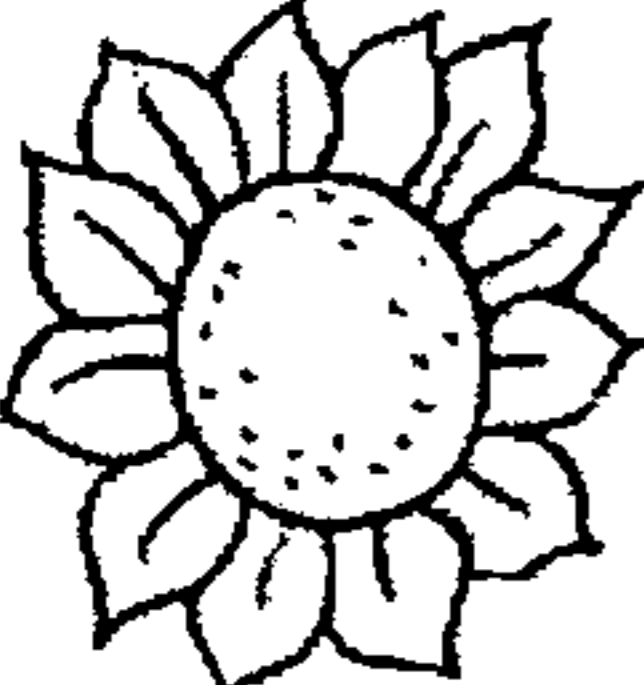
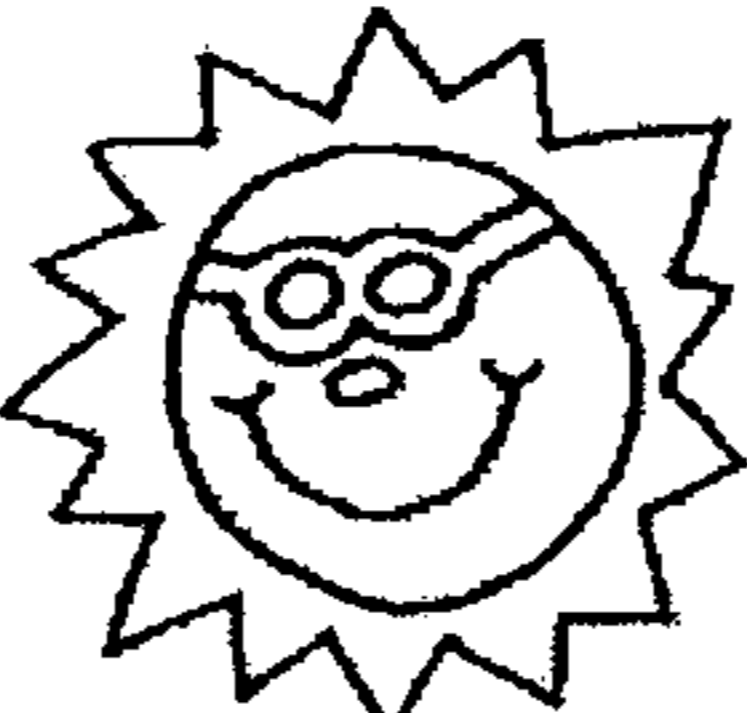
Name: _____

Look at the pattern in each row. Circle the picture that continues the pattern.
Color the pictures.

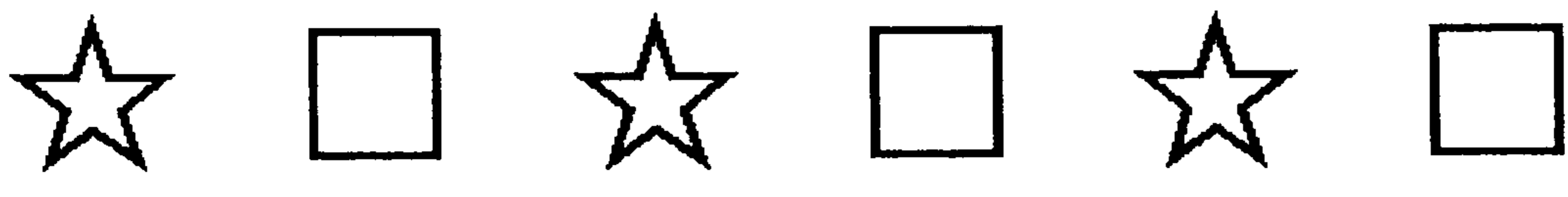
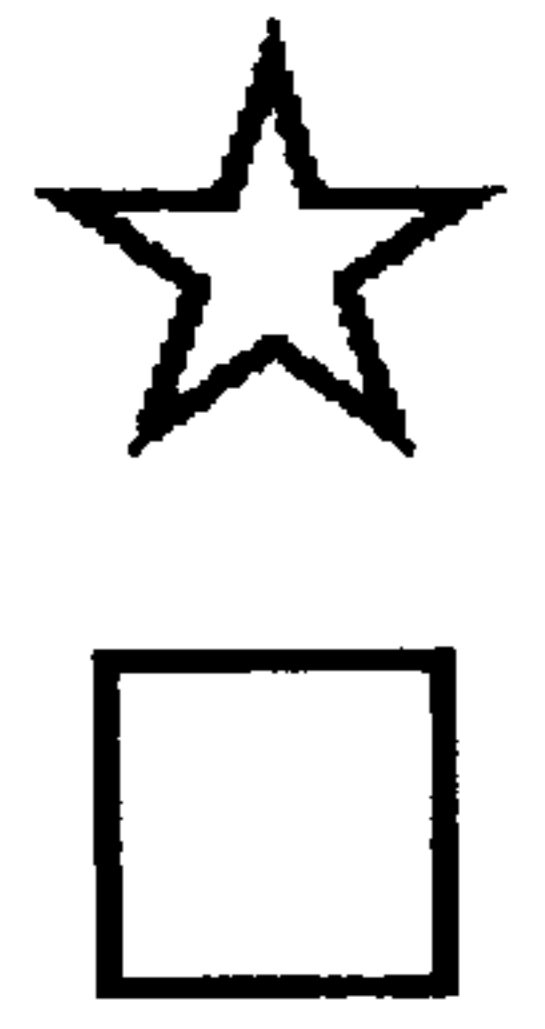
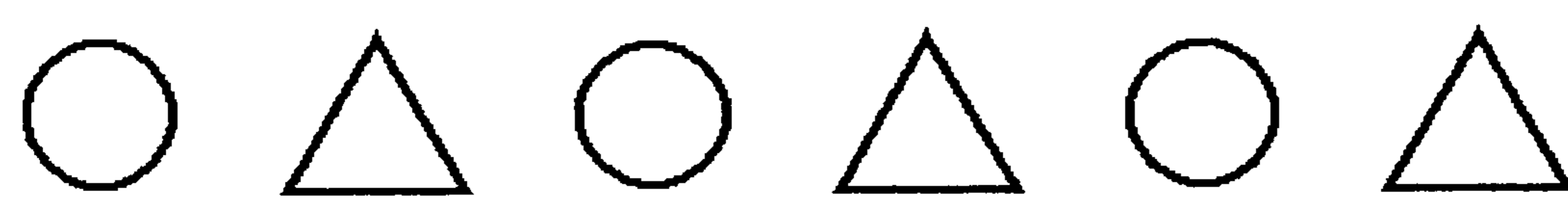
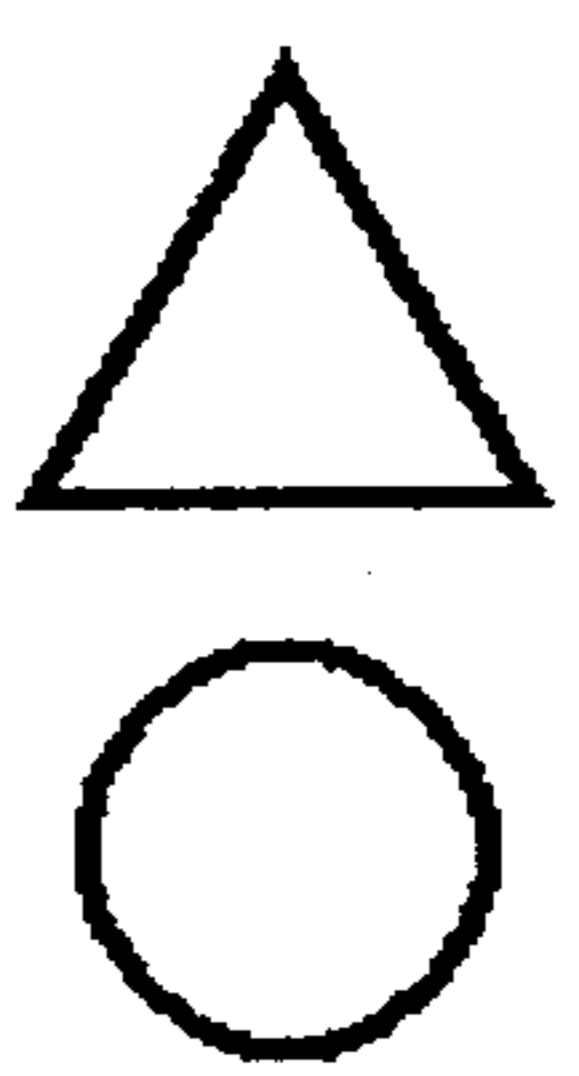
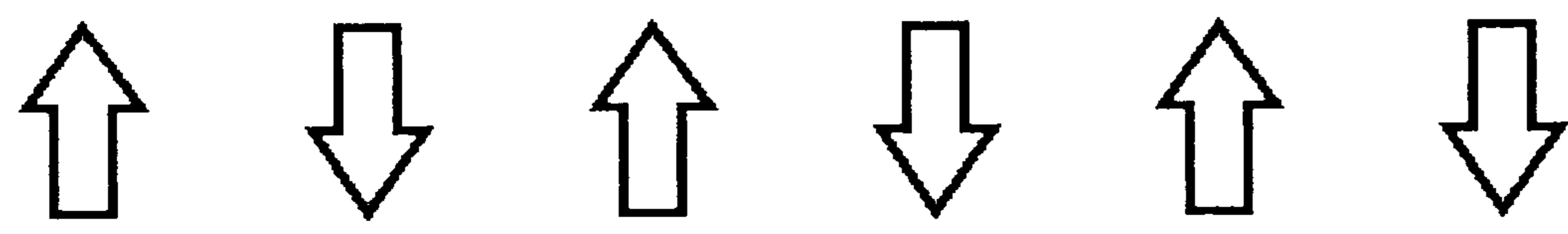
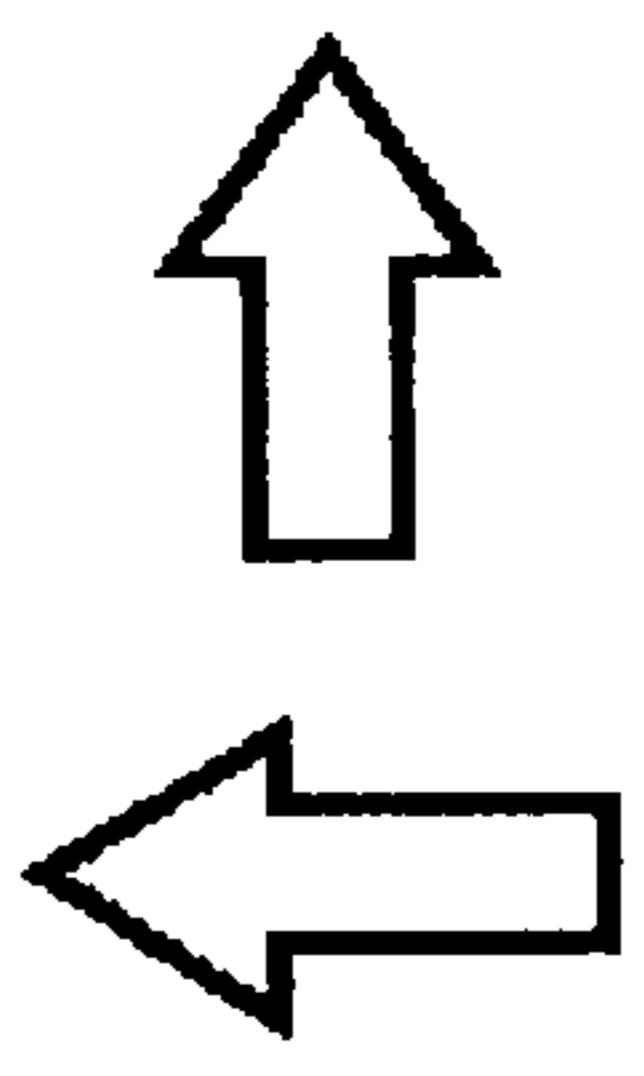
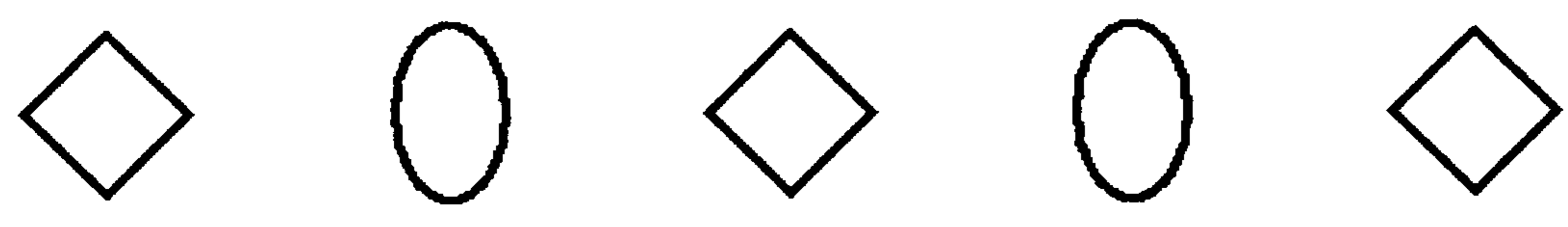
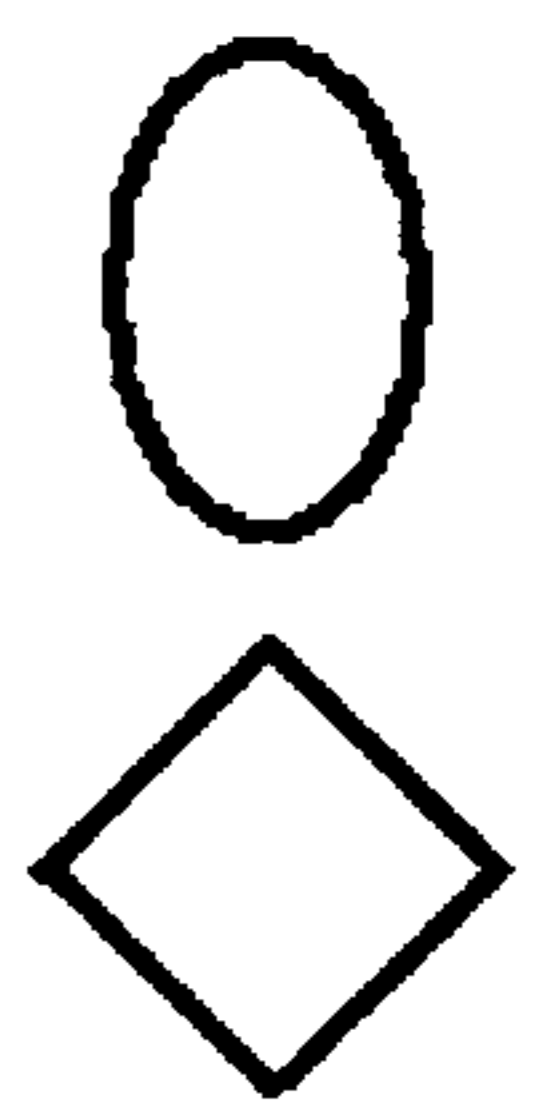
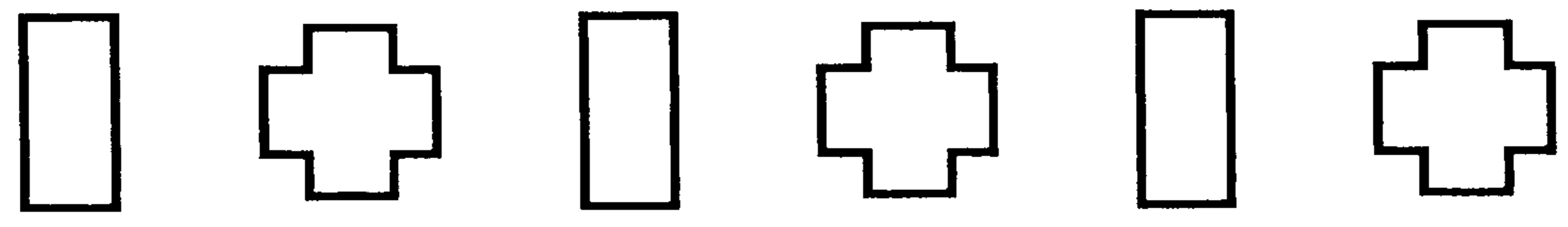
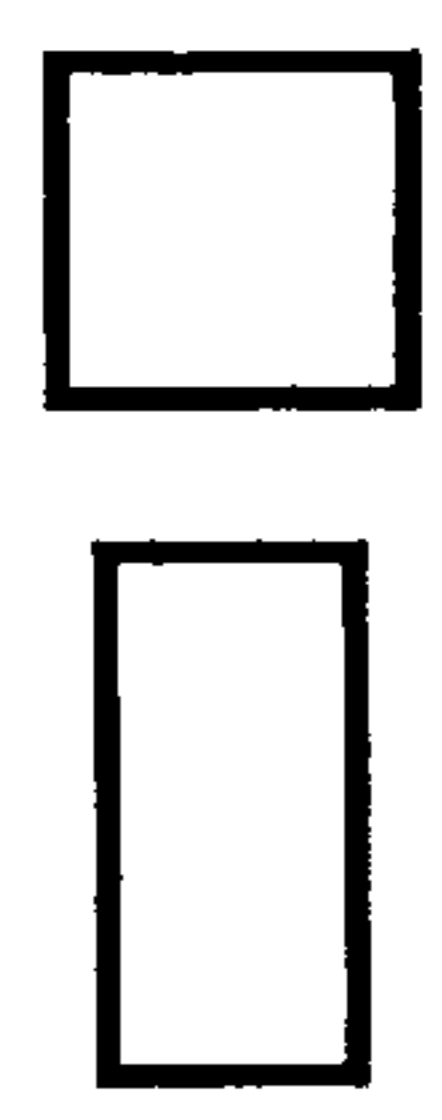

Five Senses

Create your own Five Senses Booklet.

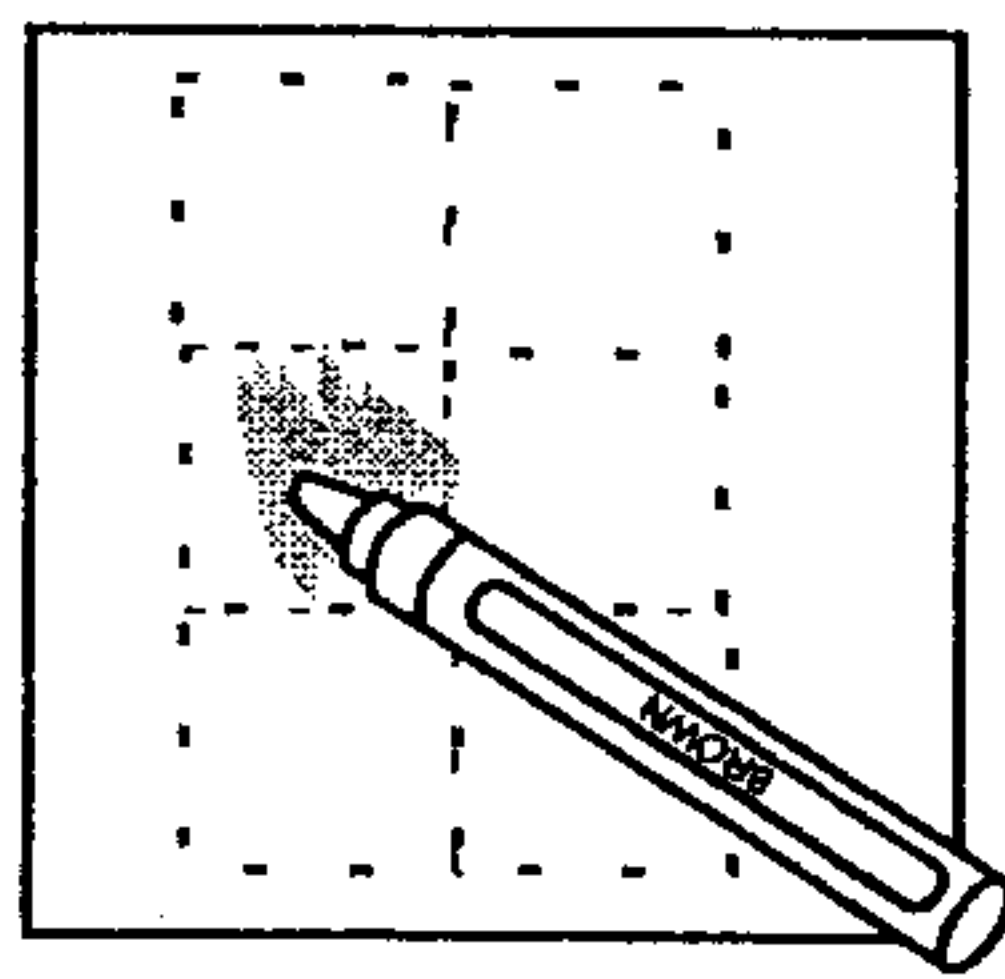

Color each sense box.

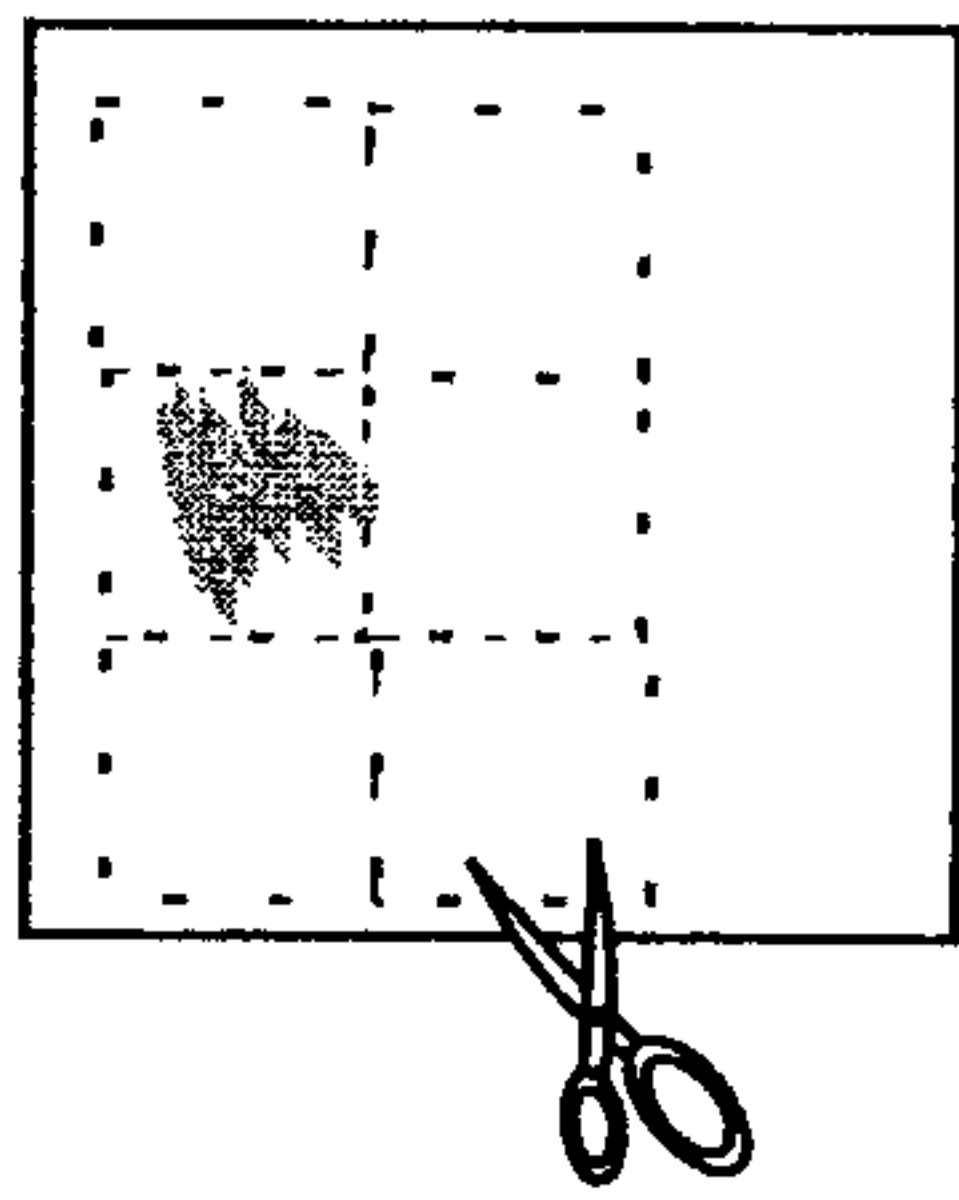

Cut along dotted line.

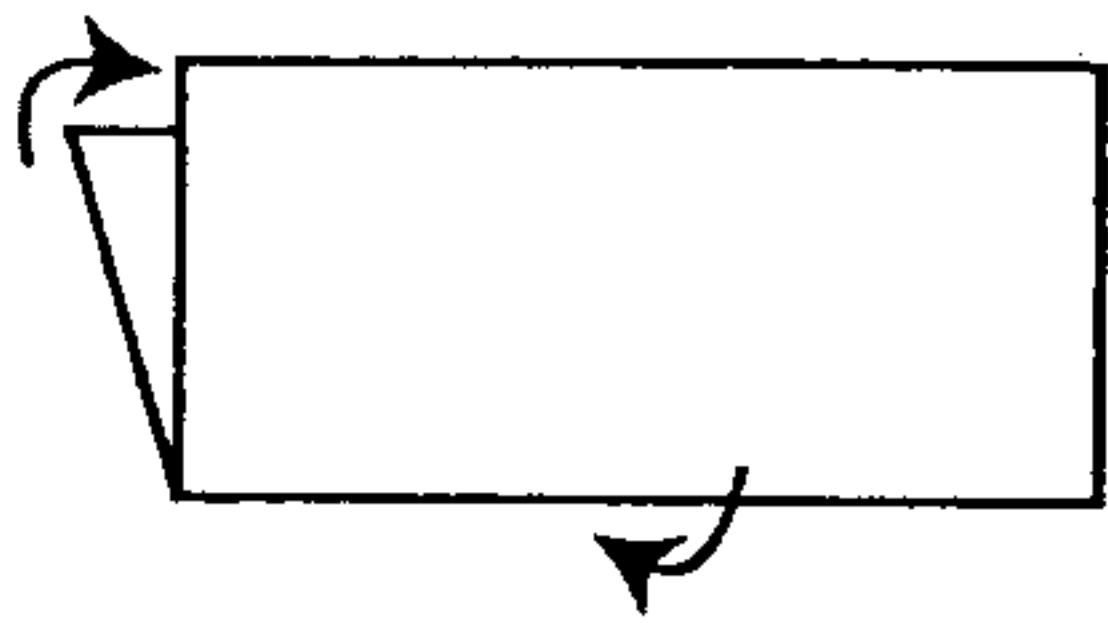

Fold construction paper in half.

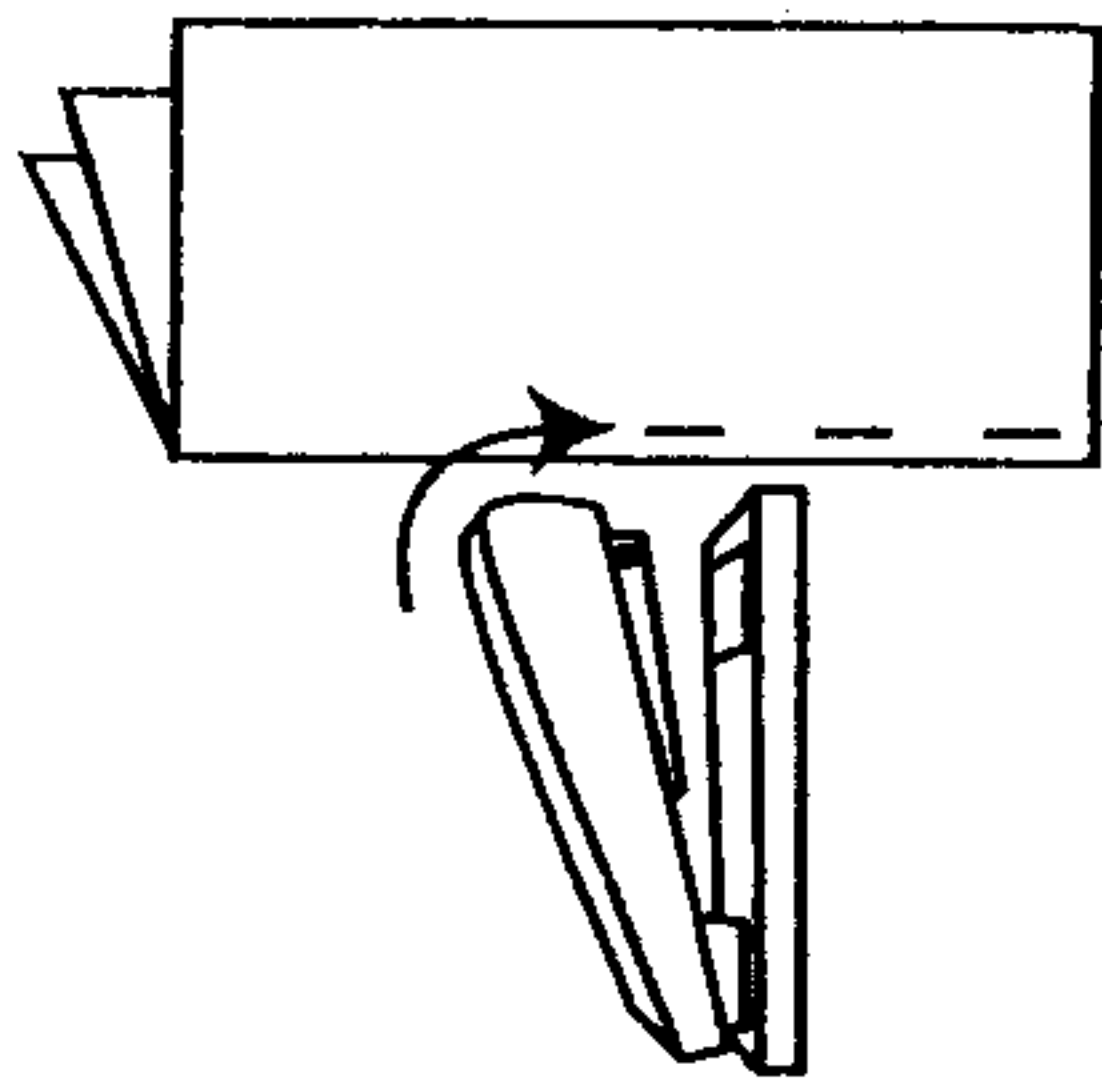

Staple along the fold, creating a booklet.

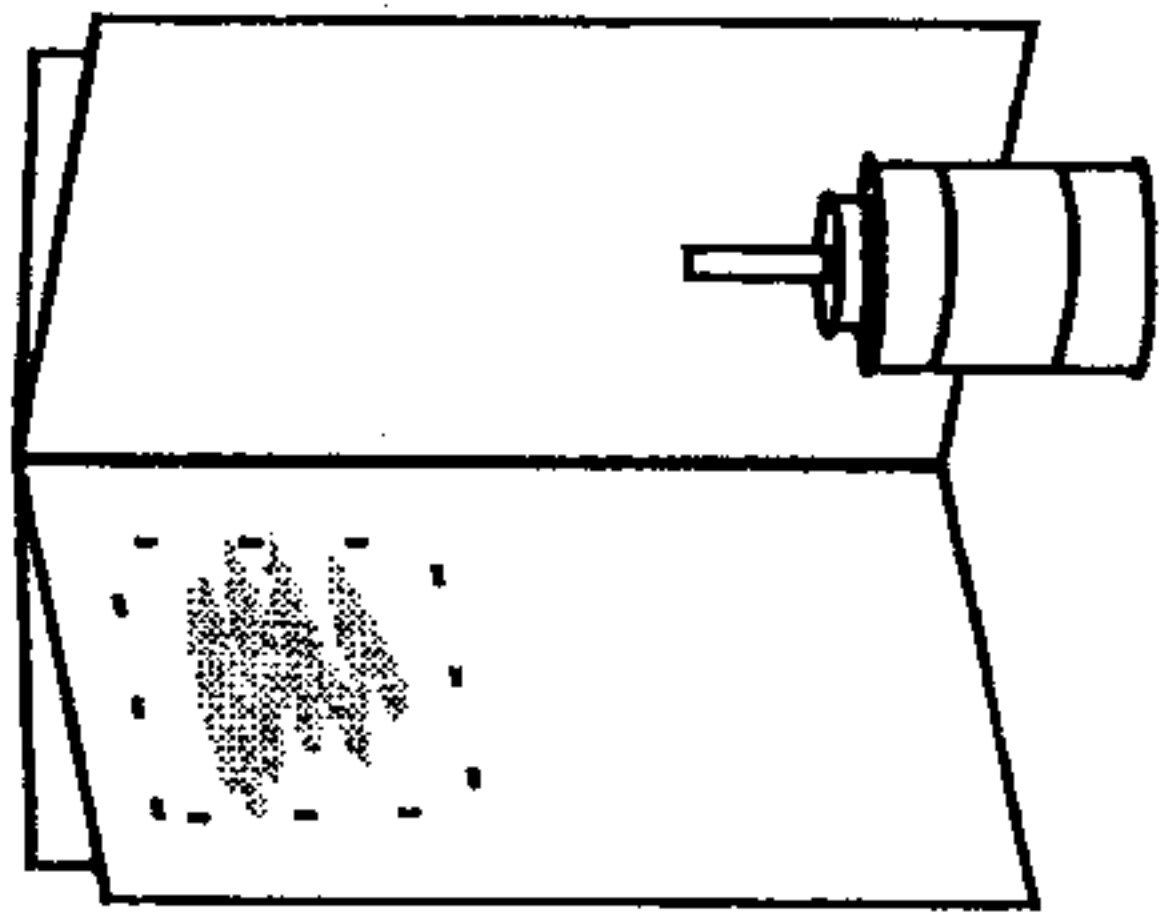

Paste each picture to the booklet so that each sense has two pages.

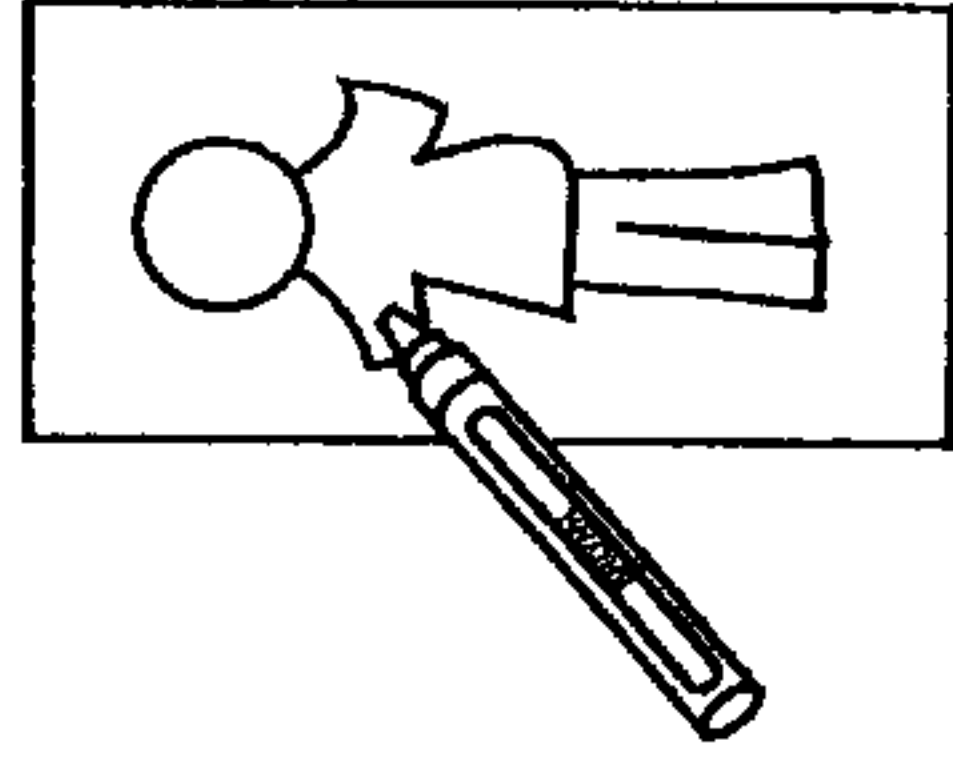

Decorate the cover.



Five Senses		
Name: _____	Sight	Sound
Touch	Taste	Smell

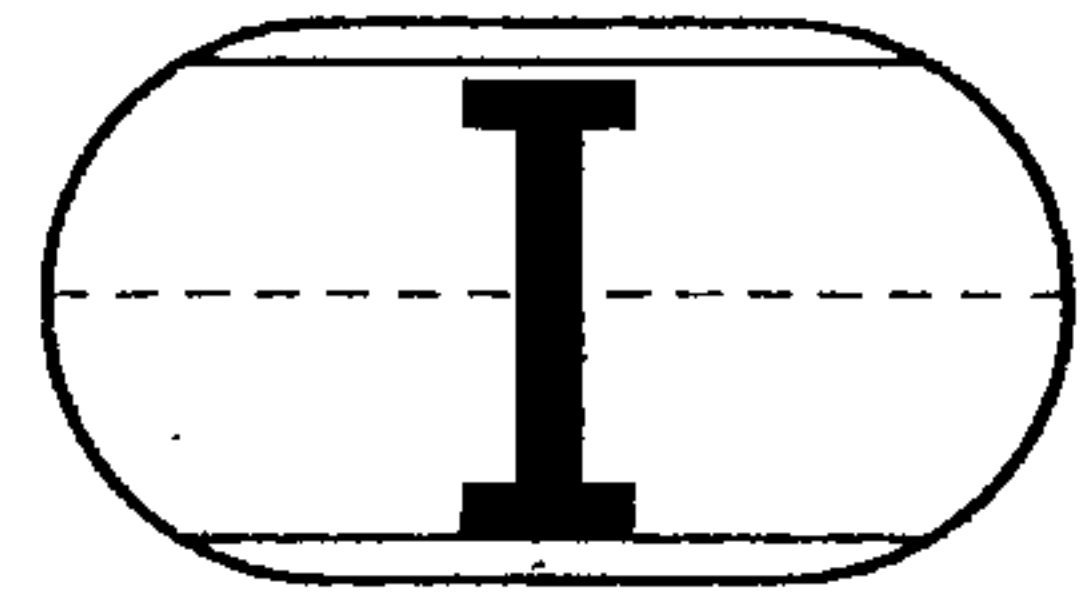

Name: _____

Write the sight word on the lines.

I Can!

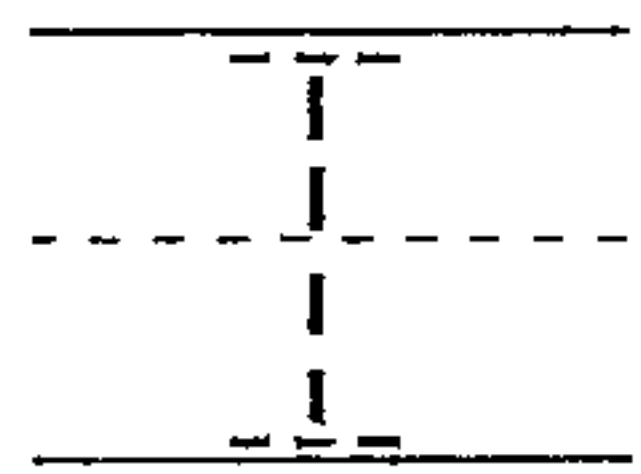

can jump.

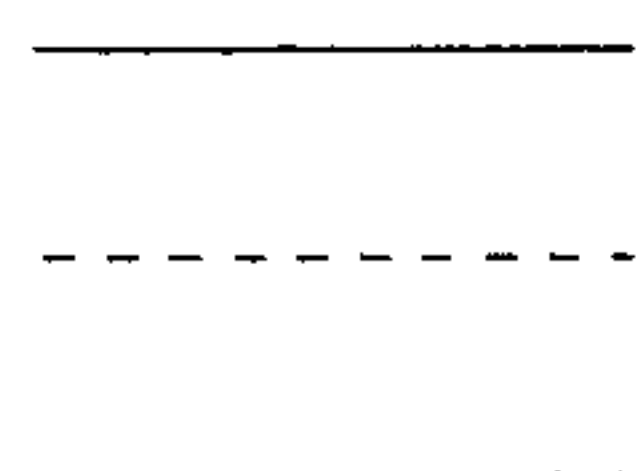

can run.

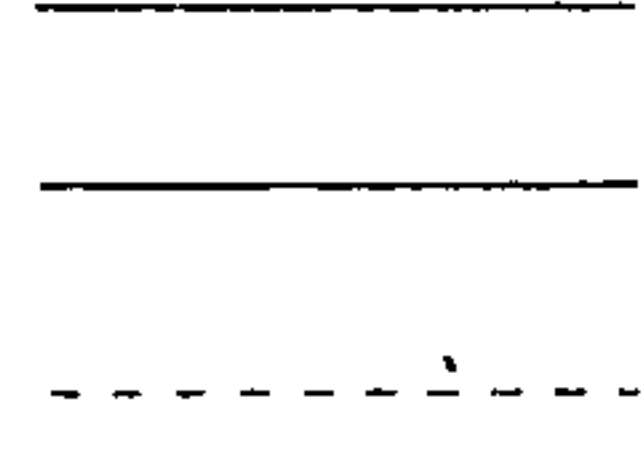

can play in the sun.

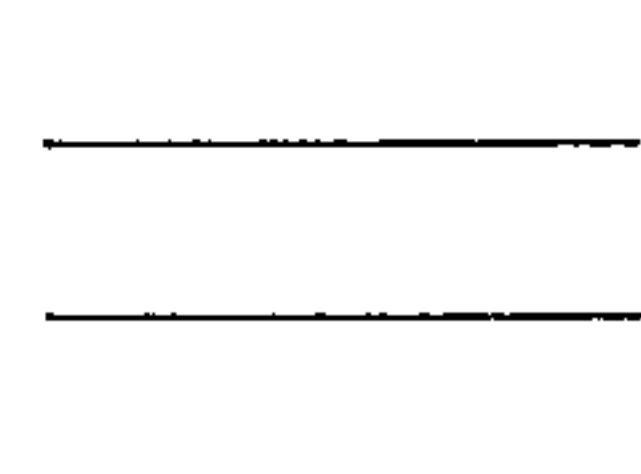

can swim.

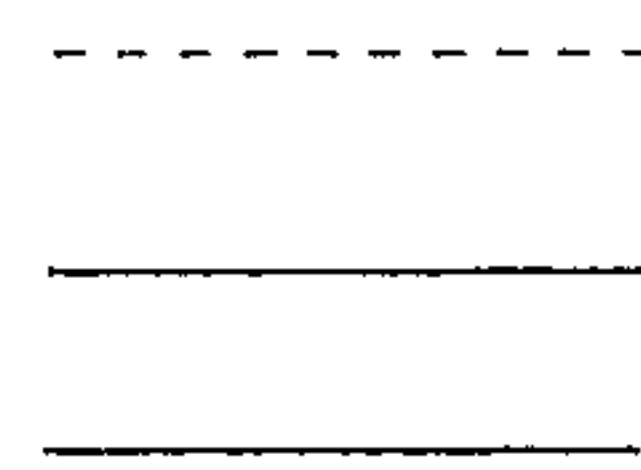

can skate.

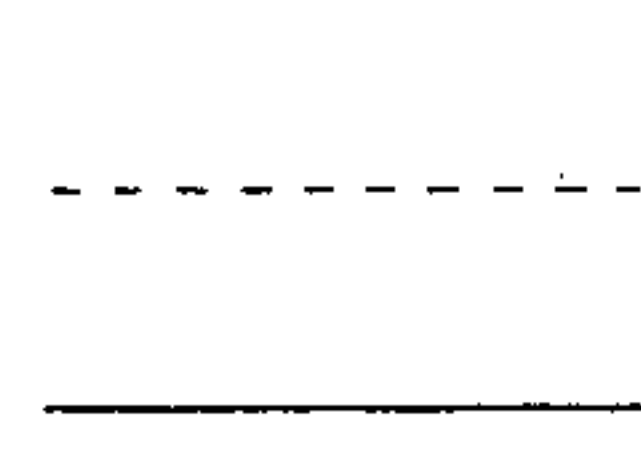

can bake a cake!

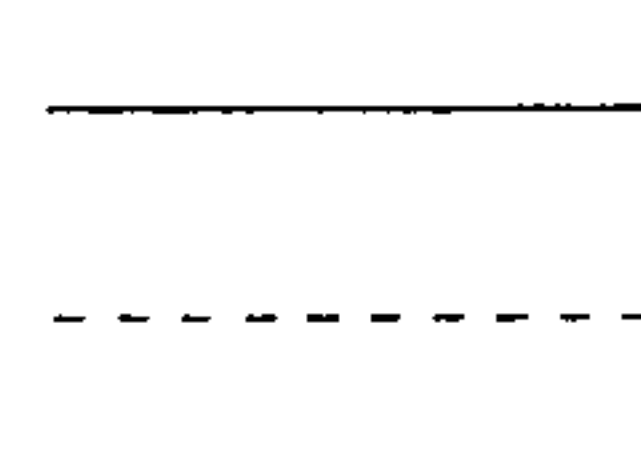

Draw yourself doing your favorite activity. Finish the sentence.

“I can _____!”

Name _____

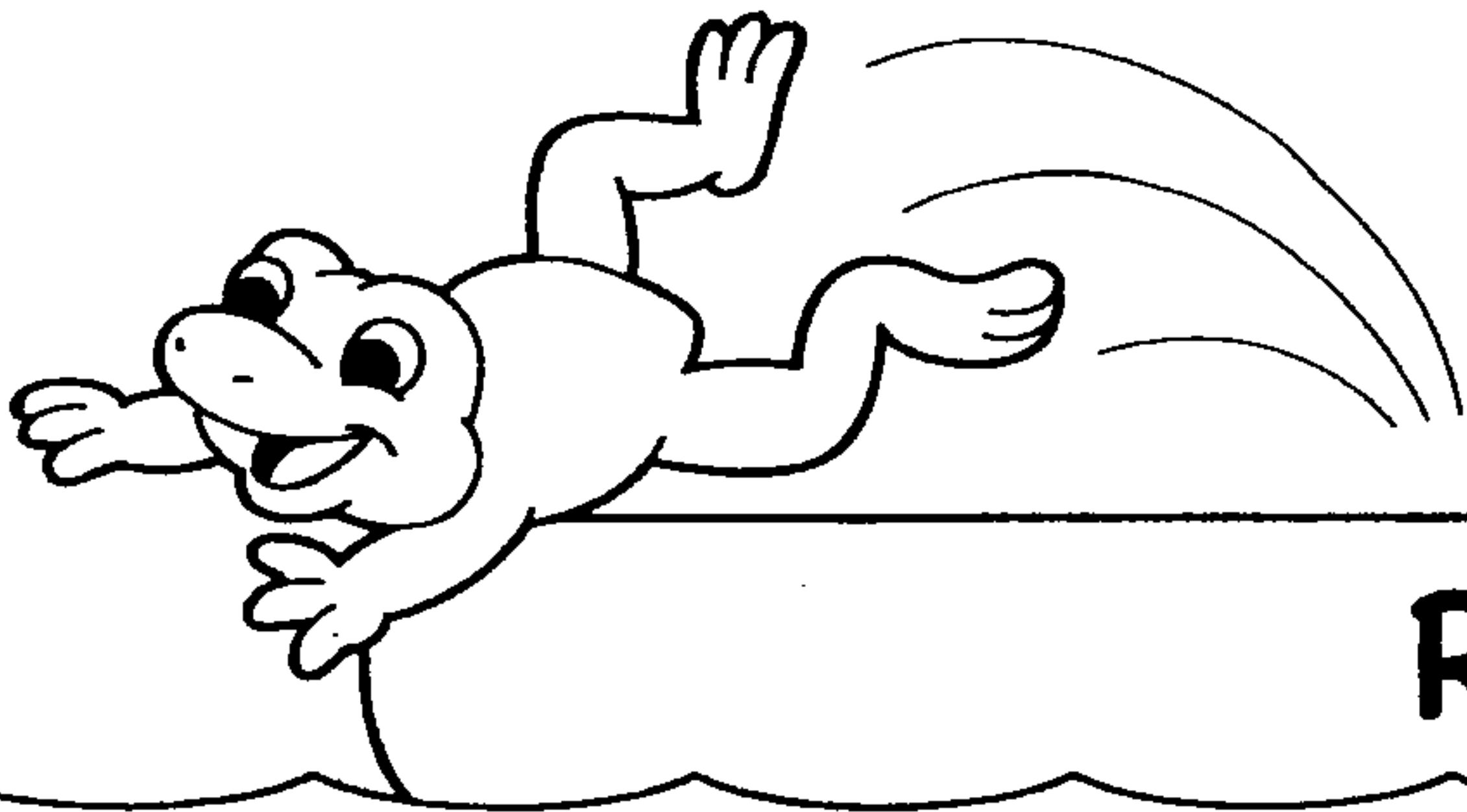

Reading Log

Book title: _____

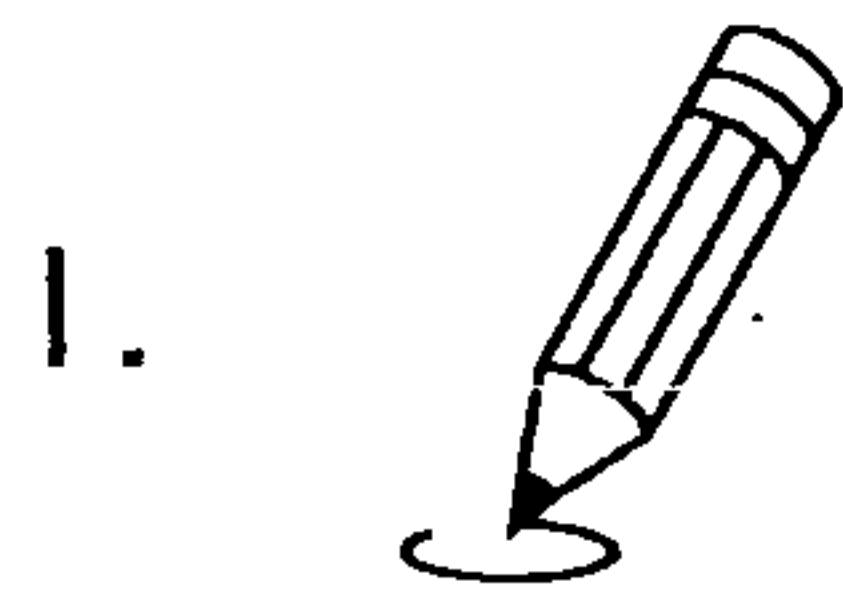
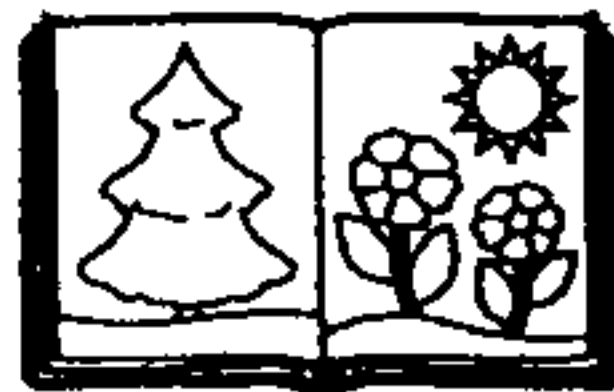

1. Do you like the **illustrations**? yes no

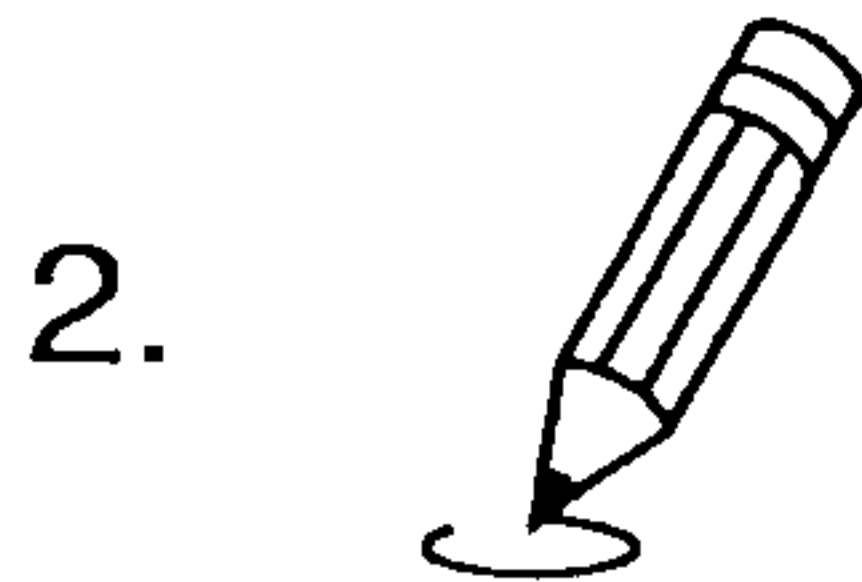
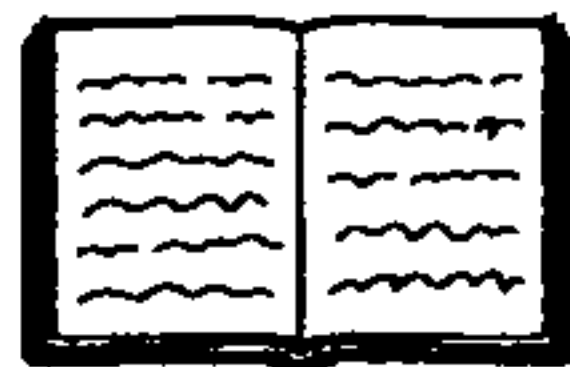

2. Do you like the **story**? yes no

3.  Write.

My favorite part of the story is _____

4.  Draw and color to show your favorite part.

Name _____

Day 6

Digital Clock

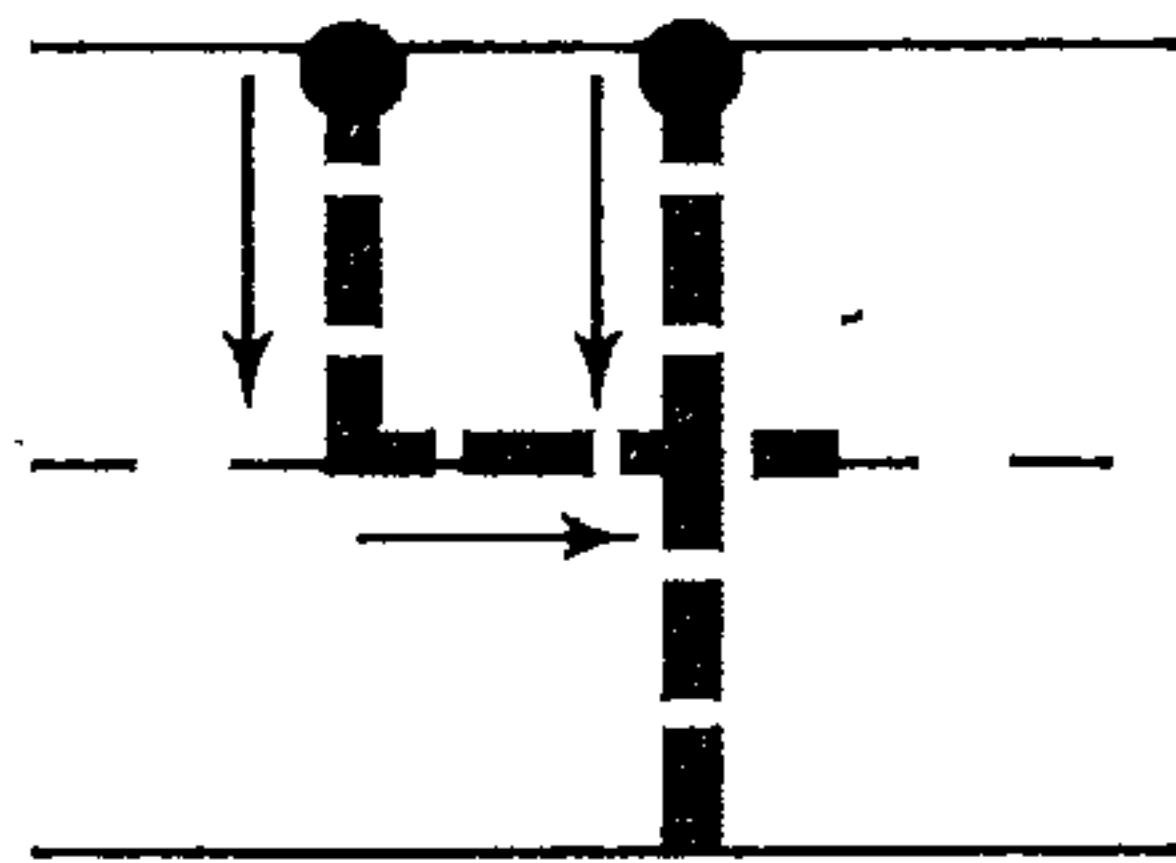

_____ o'clock

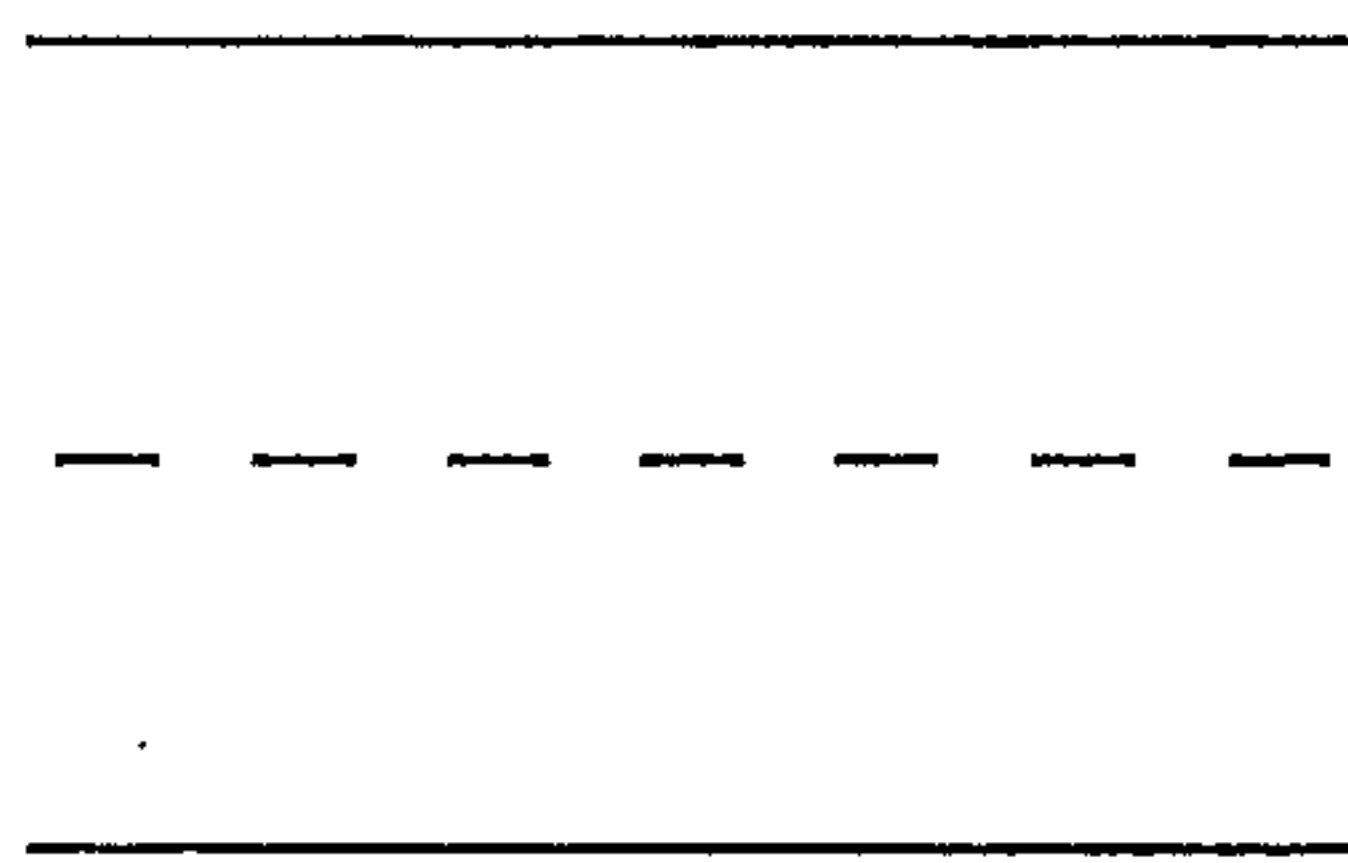
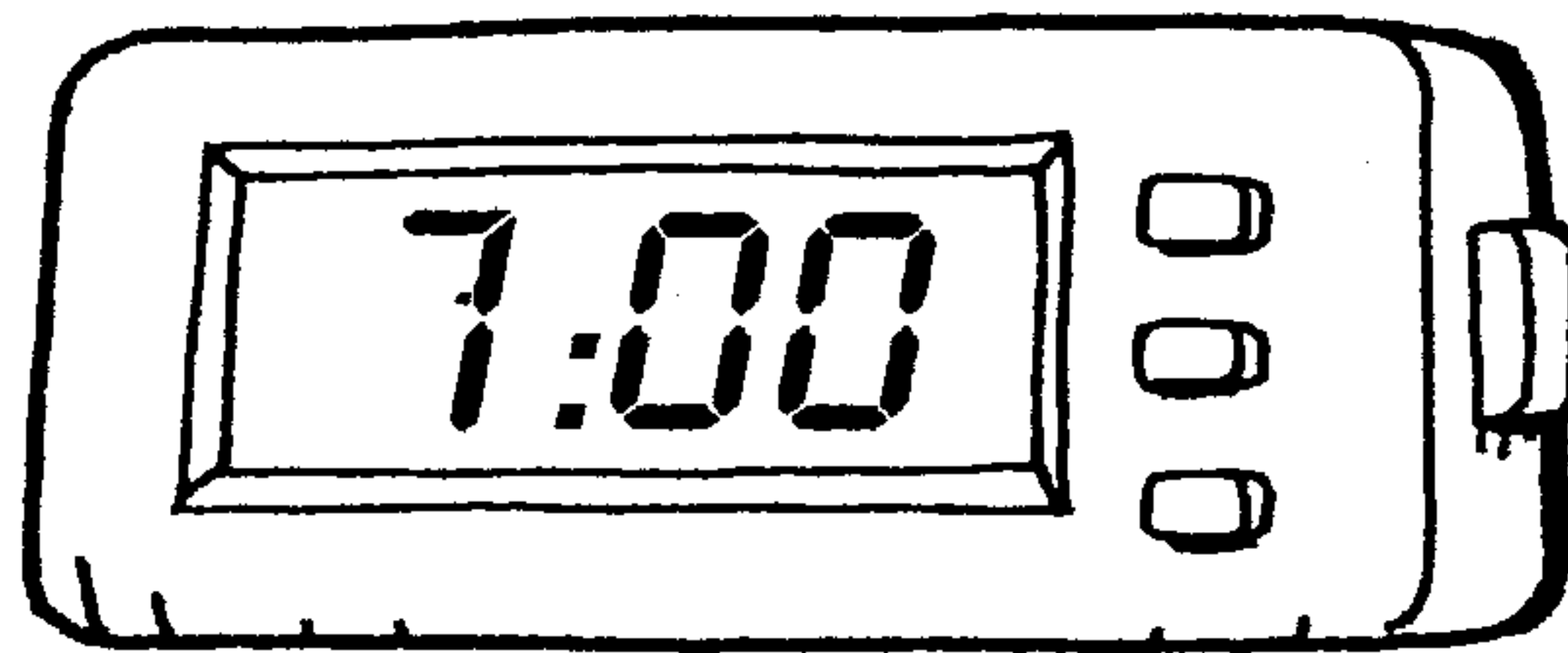

_____ o'clock

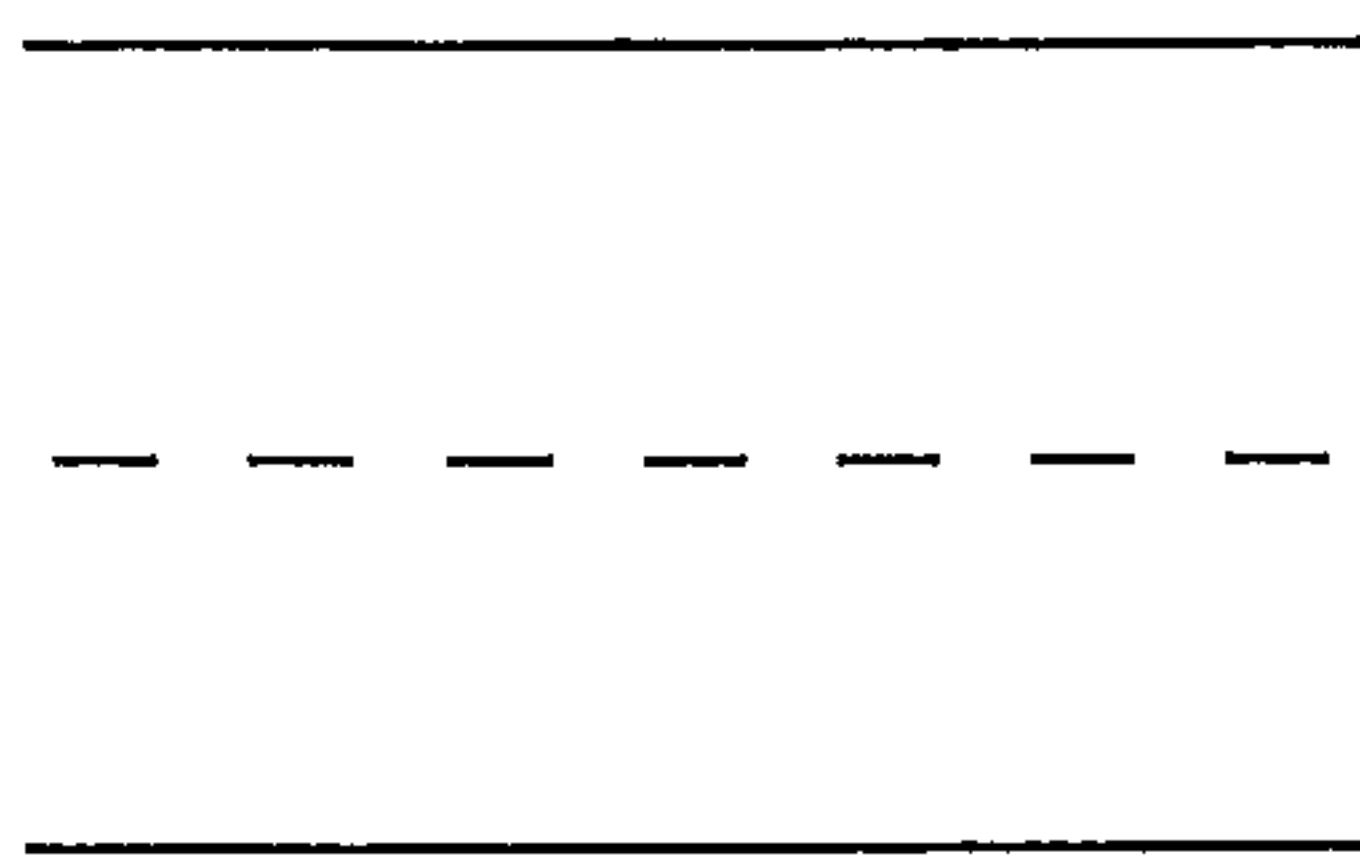

_____ o'clock

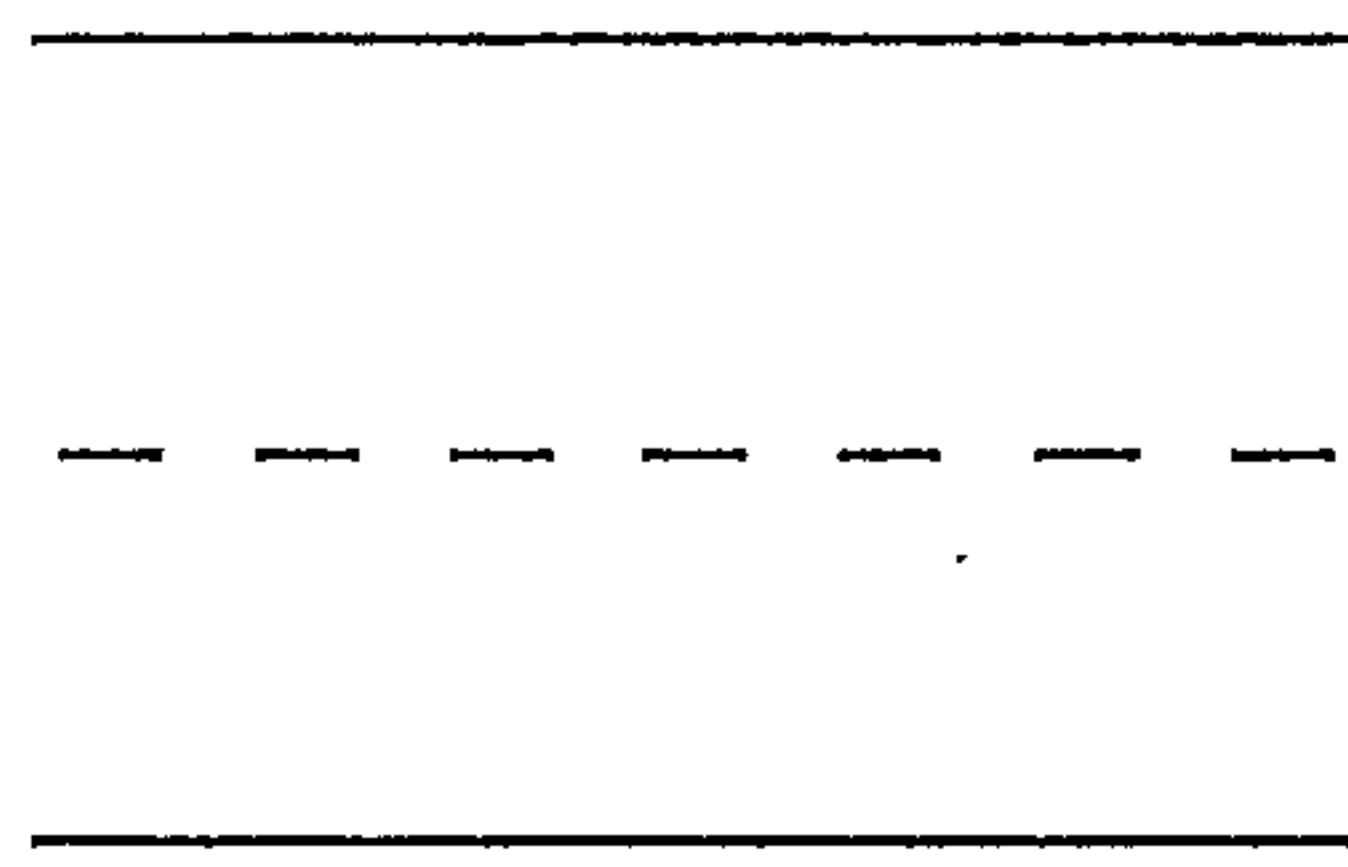
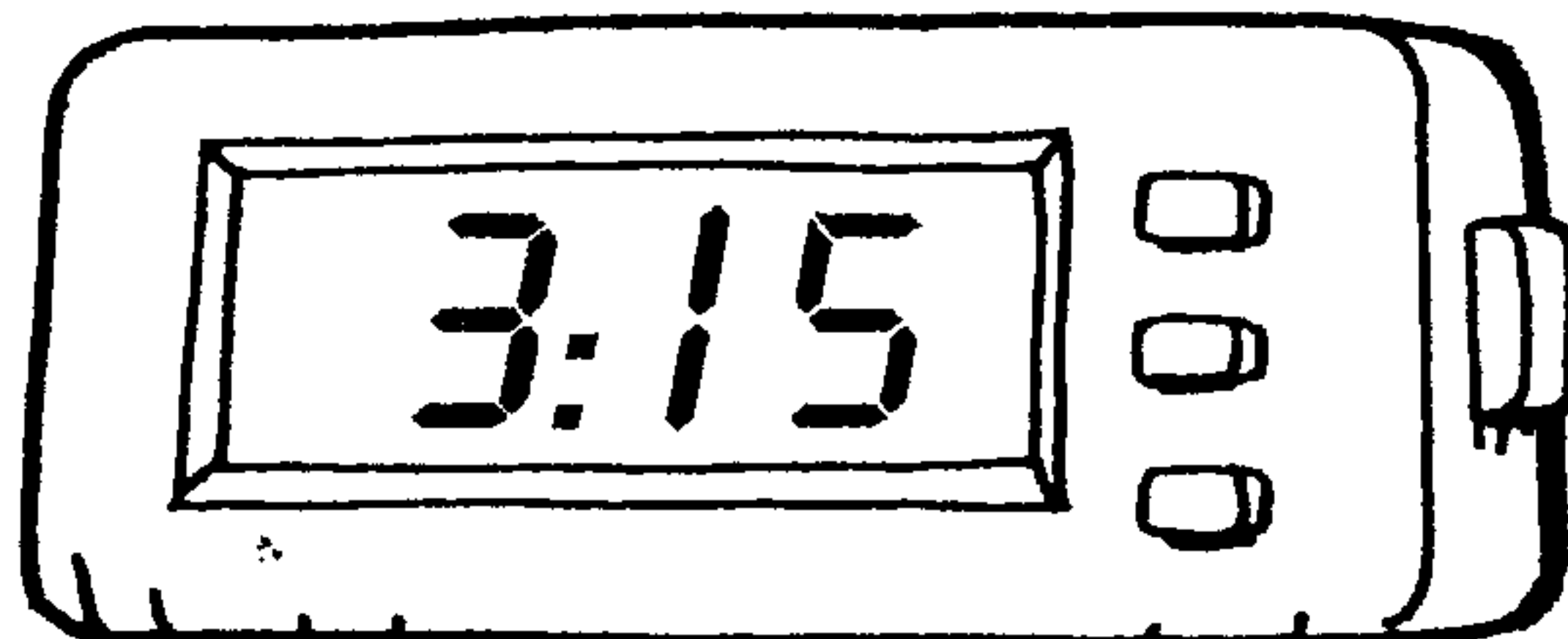

_____ o'clock

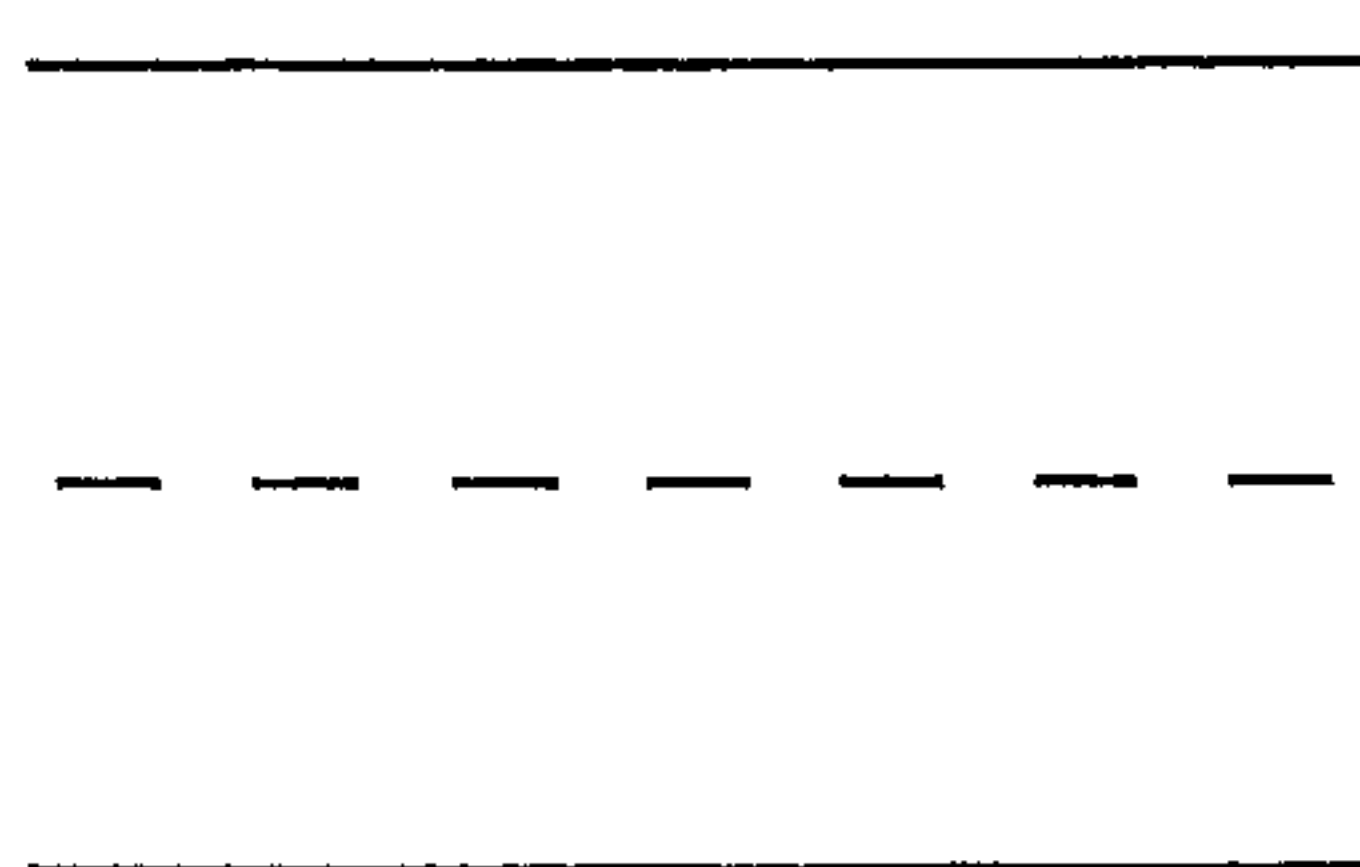

_____ o'clock

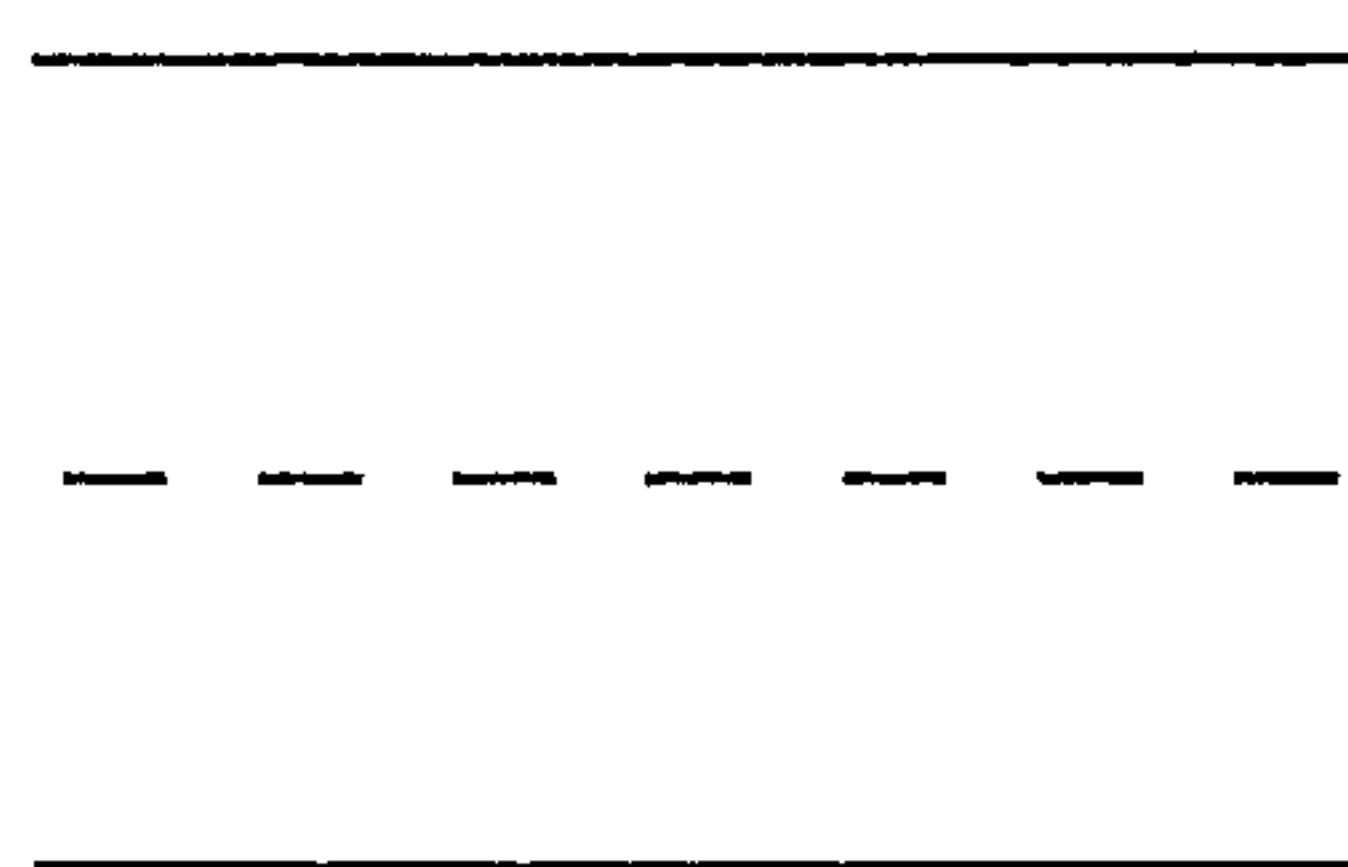
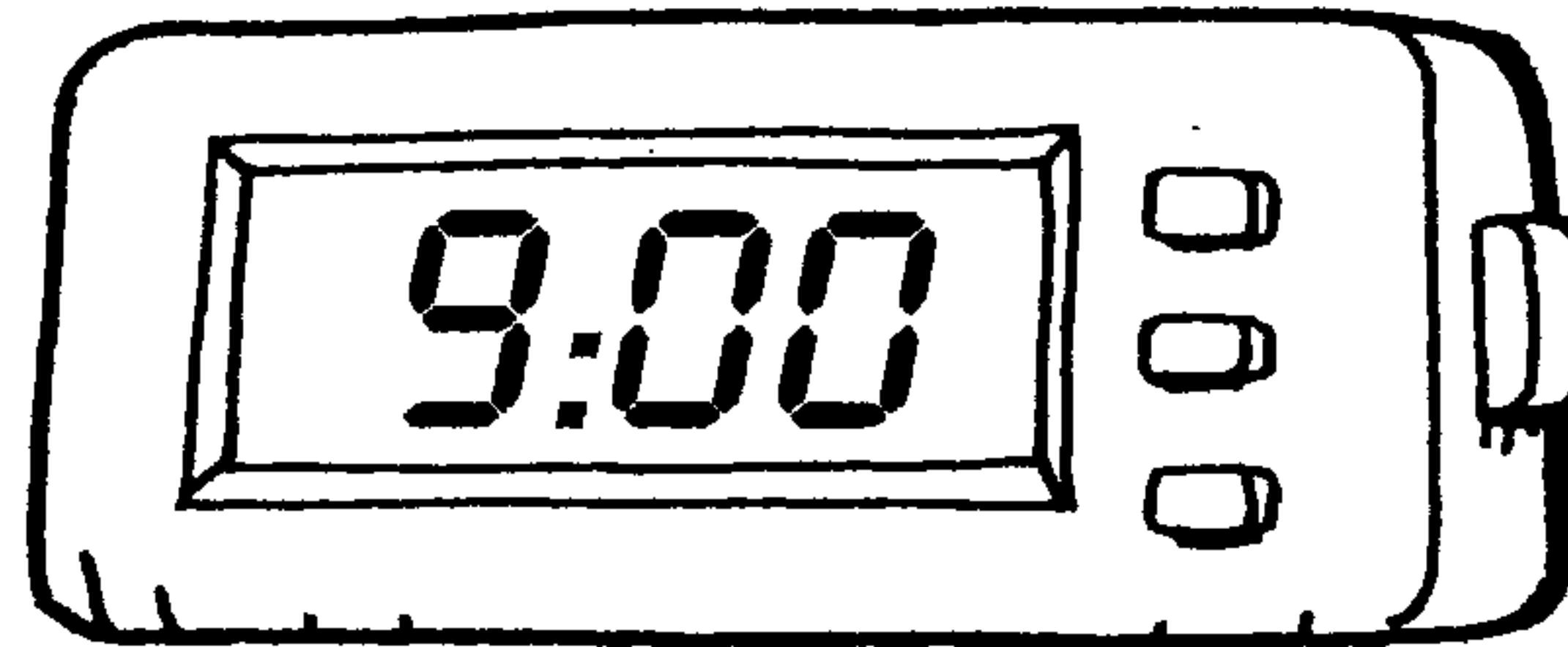

_____ o'clock

Write the number that tells the hour.

Name _____

Analog Clock

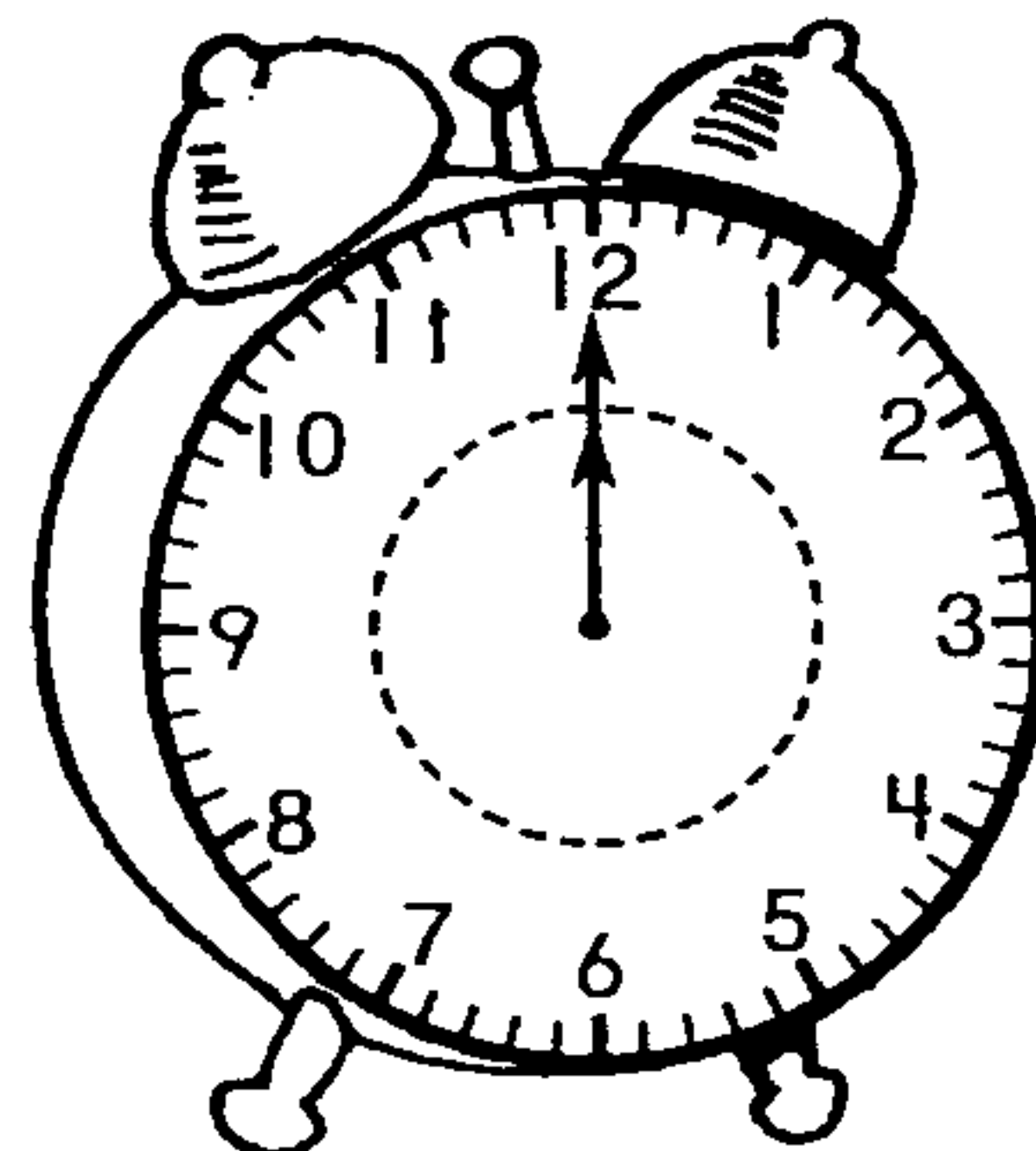
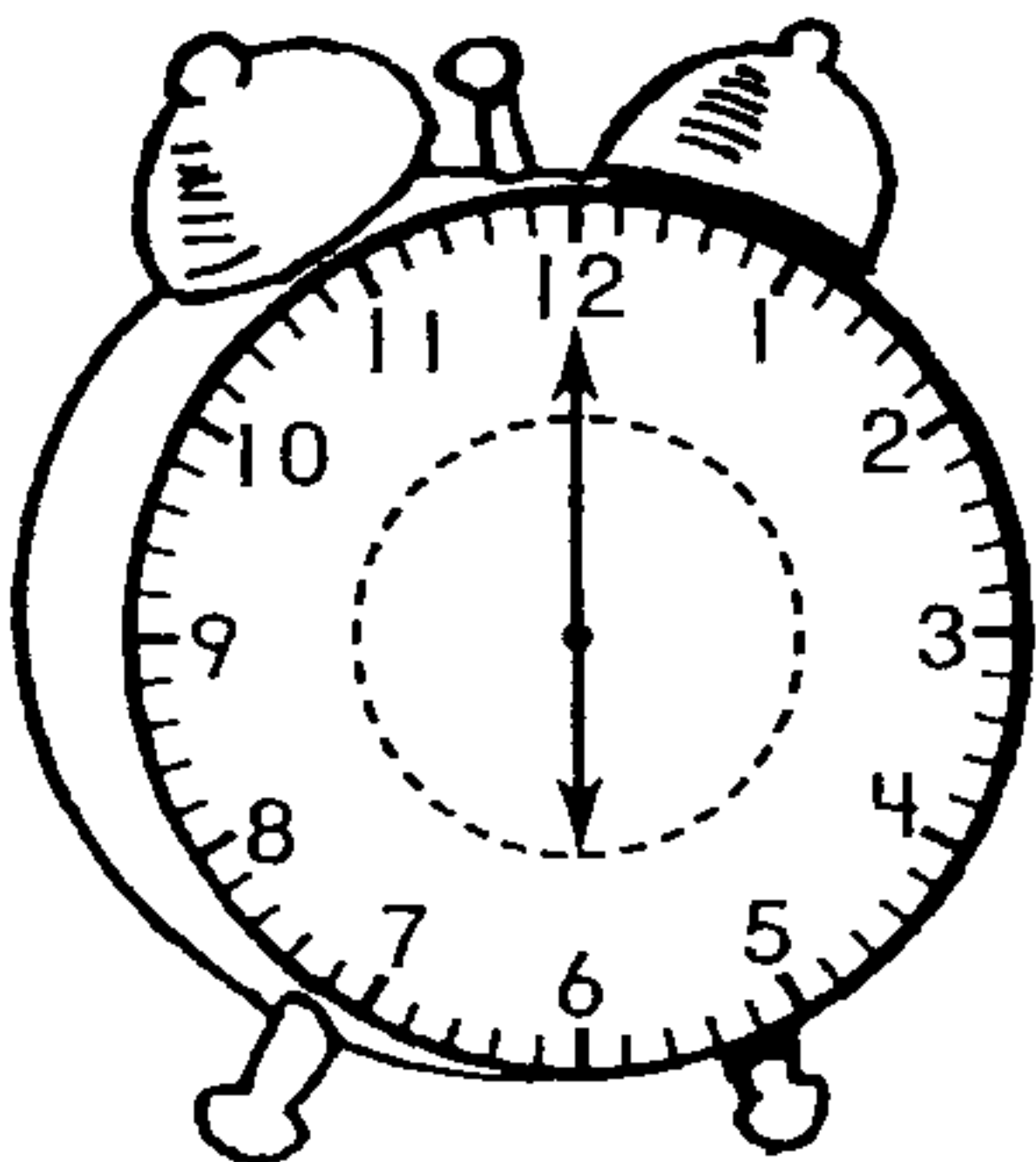
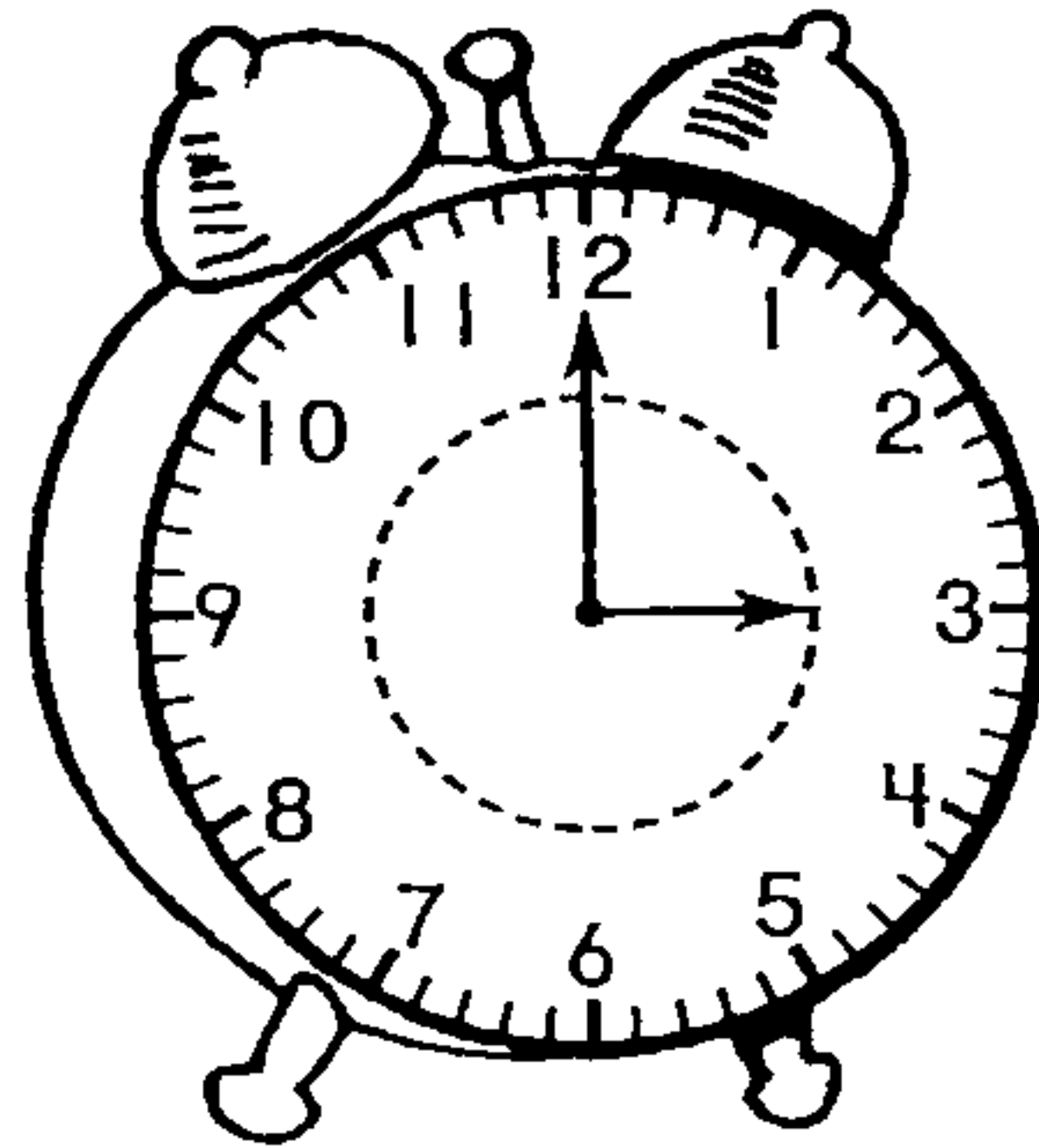
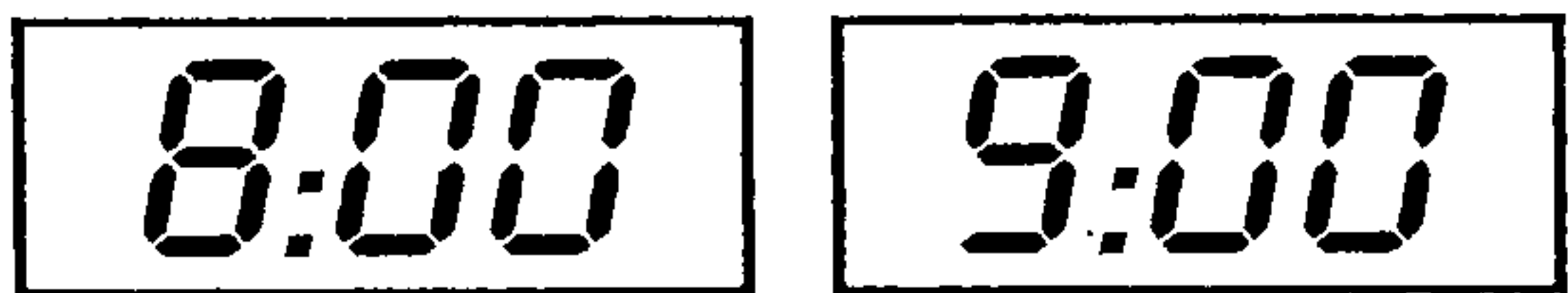
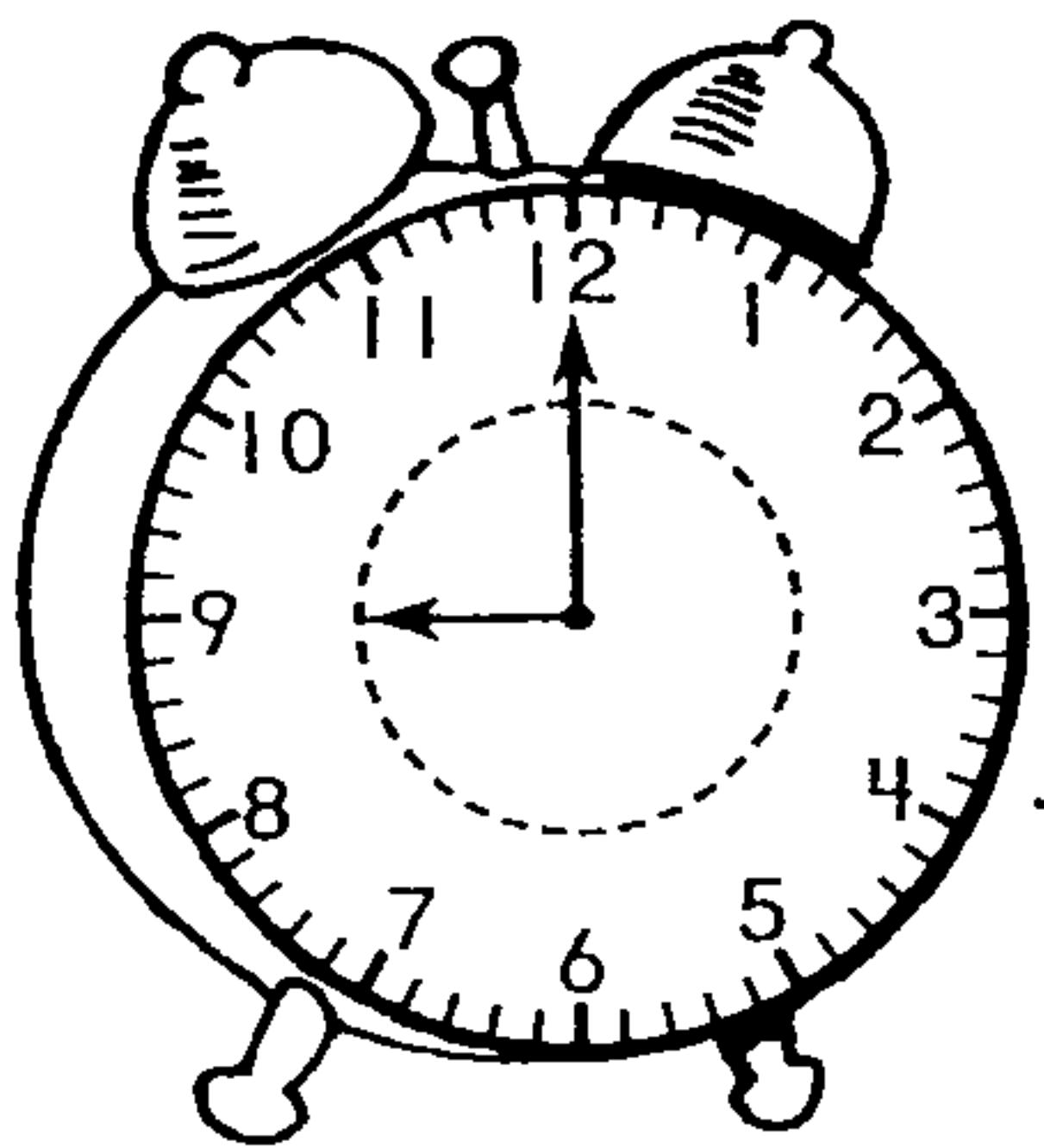
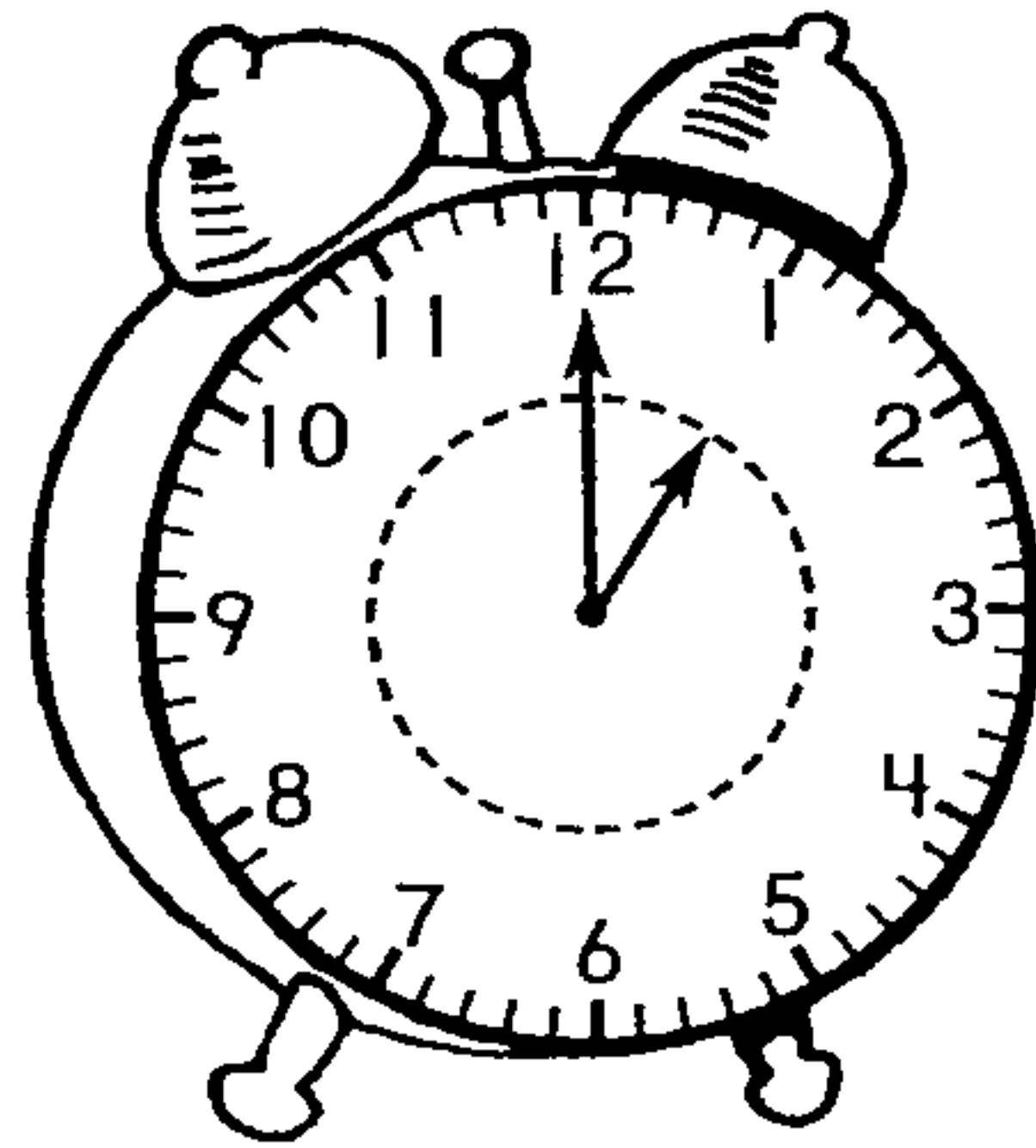
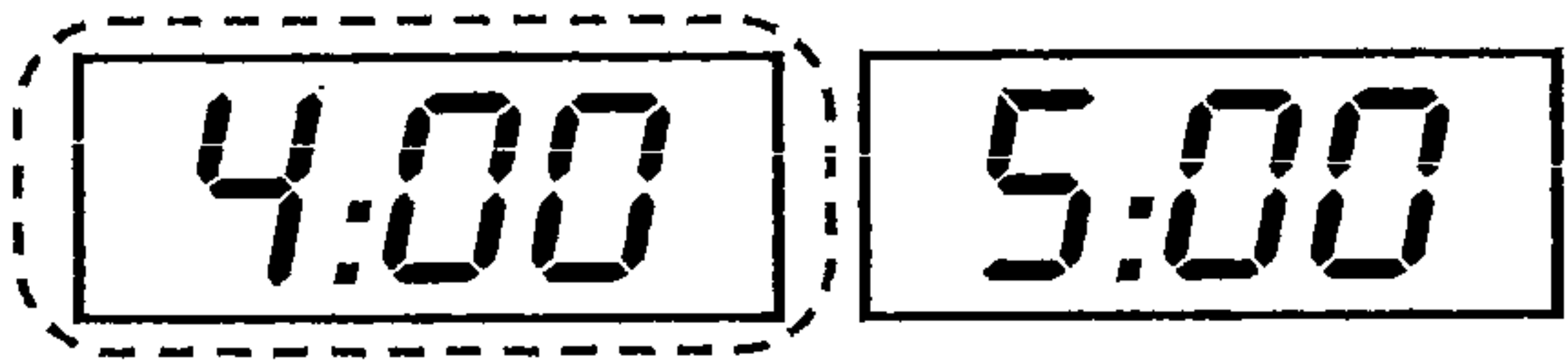
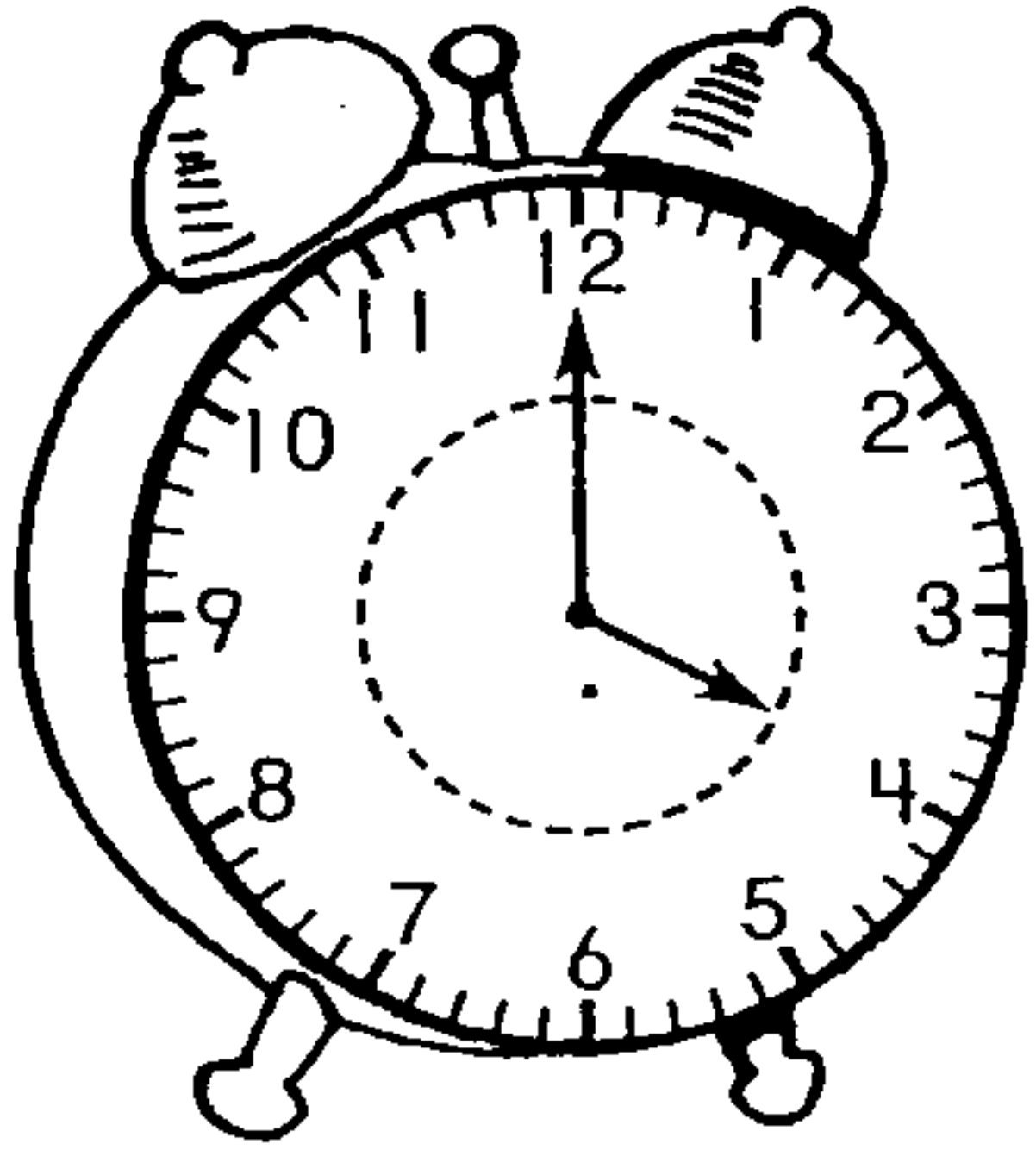

Read the time. Circle the digital clock that shows the same hour as the clock with hands.

can

Name: _____

I can ride a bike!

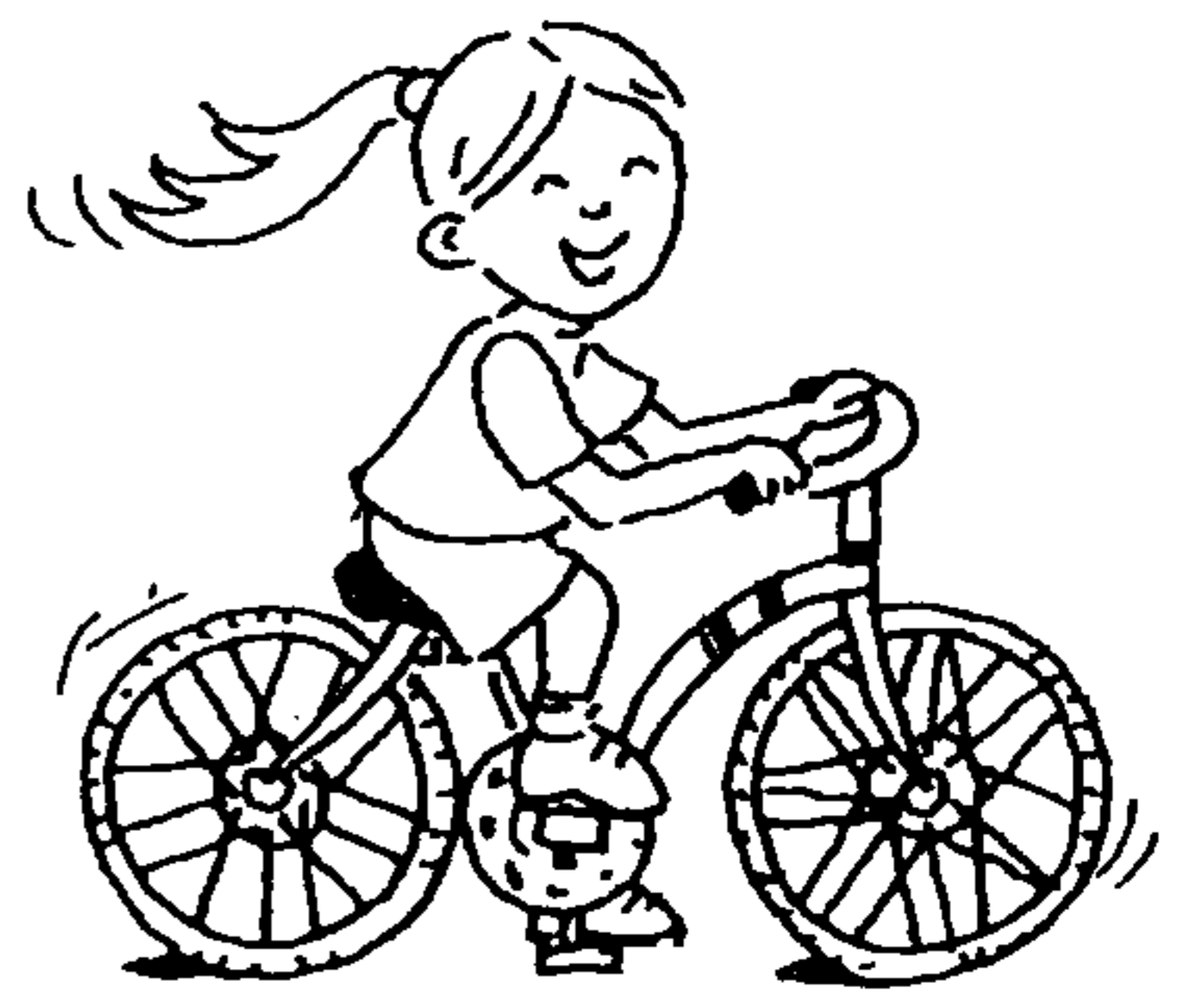

Trace the word and say it aloud:

can can can

Write the word:

Cut out the letters at the bottom of the page and mix them up. Then paste them in the right squares to finish the sentence:

I [] [] [] ride a bike!

Write the word to finish the sentence:

I _____ ride a bike!

Write your own sentence using the word:

c a n

Name _____

Day 7

Numbers on a Calendar

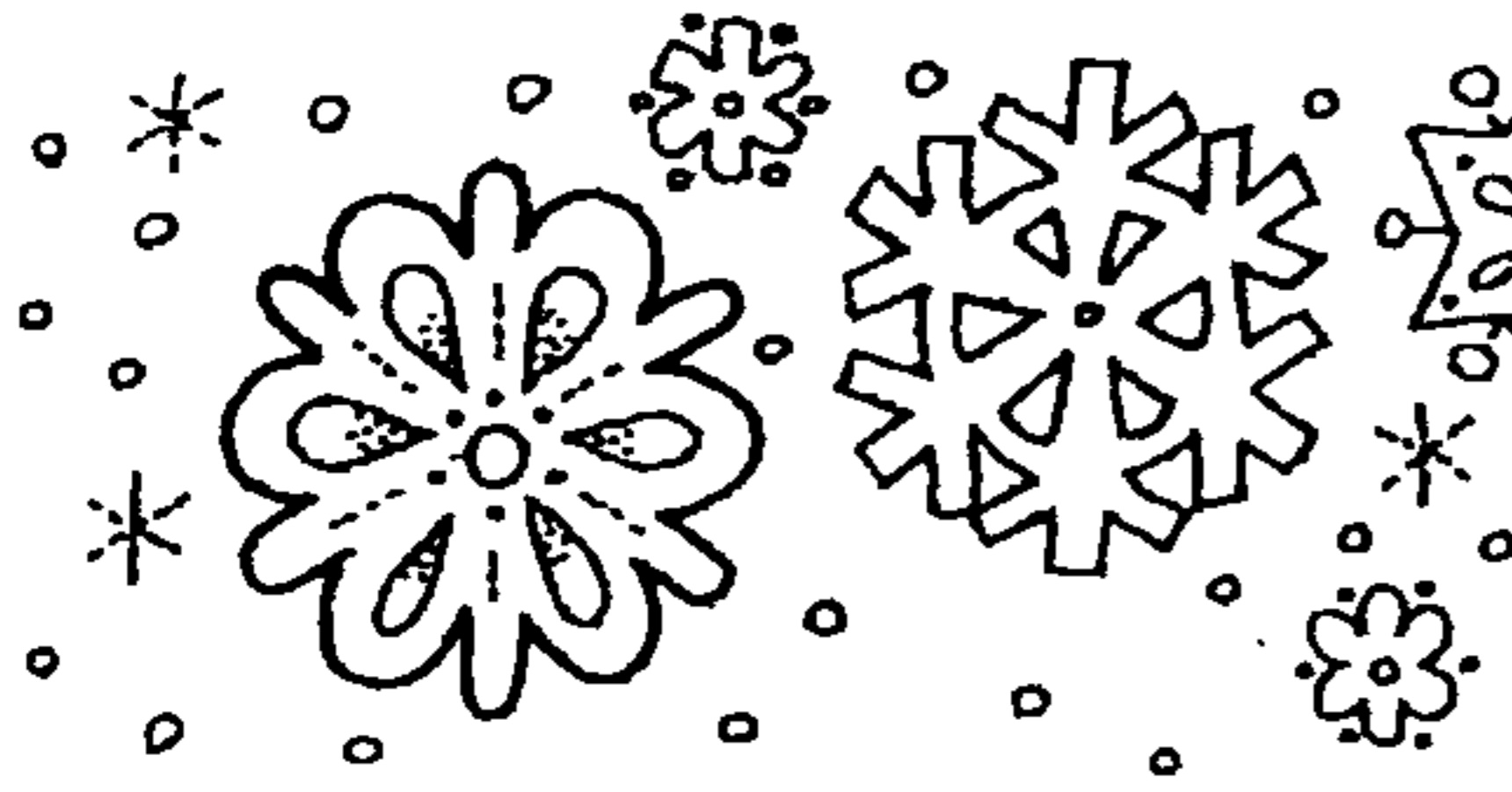

December

Sunday	Monday	Tuesday	Wednesday	Thursday	Friday	Saturday
	1	2	3	4	5	6
7	8		10		12	
14	15	16	17		19	20
21		23	24	25		27
28			31			

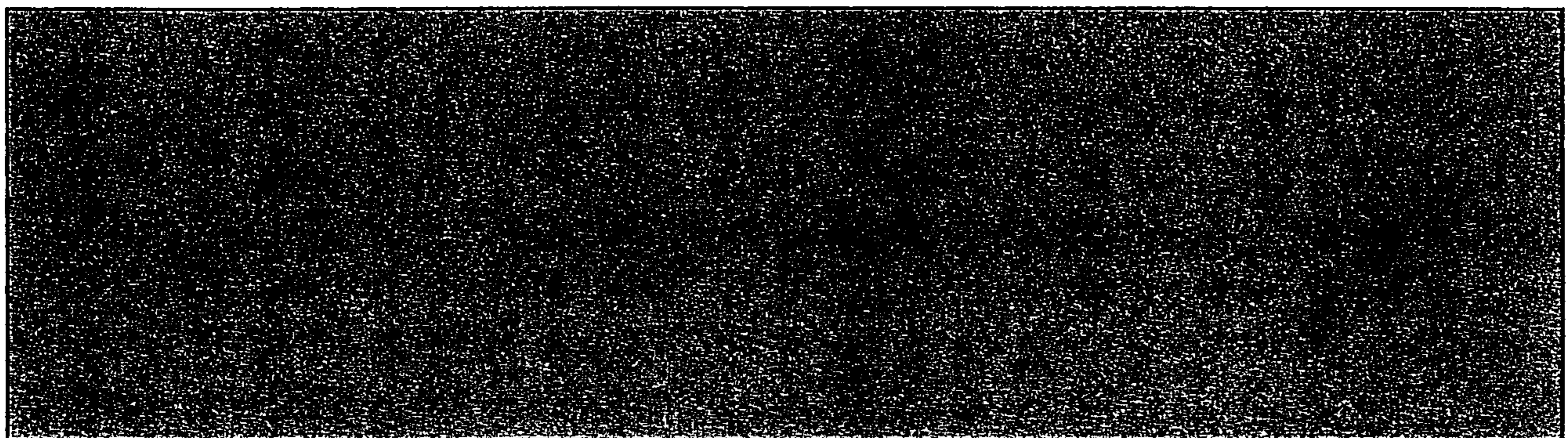

Write the missing numbers.

Circle the number that comes after 10. Use blue to color the number that comes before 28. Draw a line under the number that is the same as today's date.

Name _____

Day 7

Use a Calendar

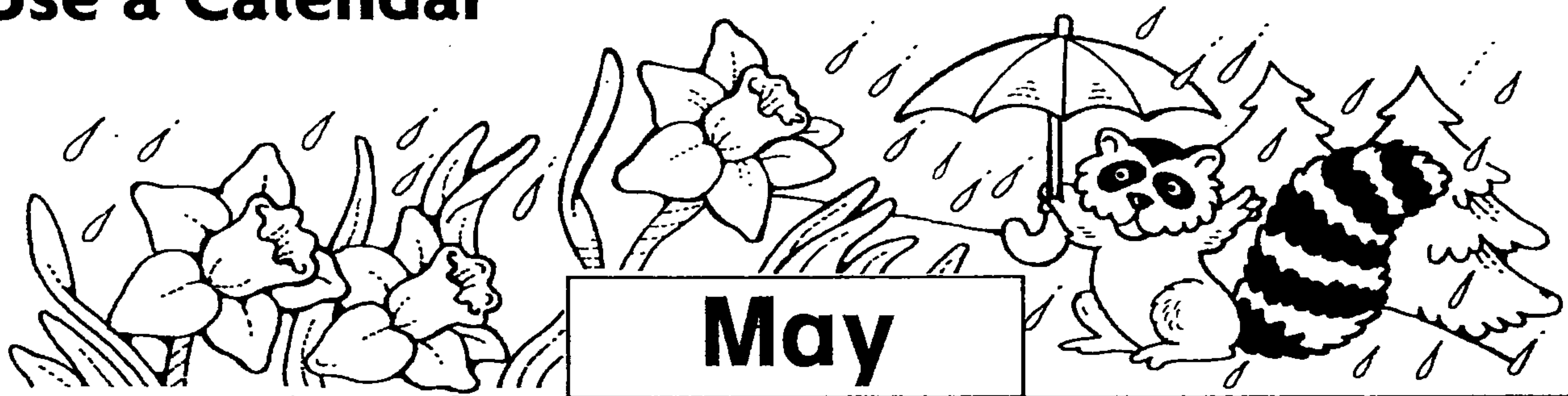

Sunday	Monday	Tuesday	Wednesday	Thursday	Friday	Saturday
				1	2	3
4	5	6	7	8	9	10
11	12	13	14	15	16	17
18	19	20	21	22	23	24
25	26	27	28	29	30	31

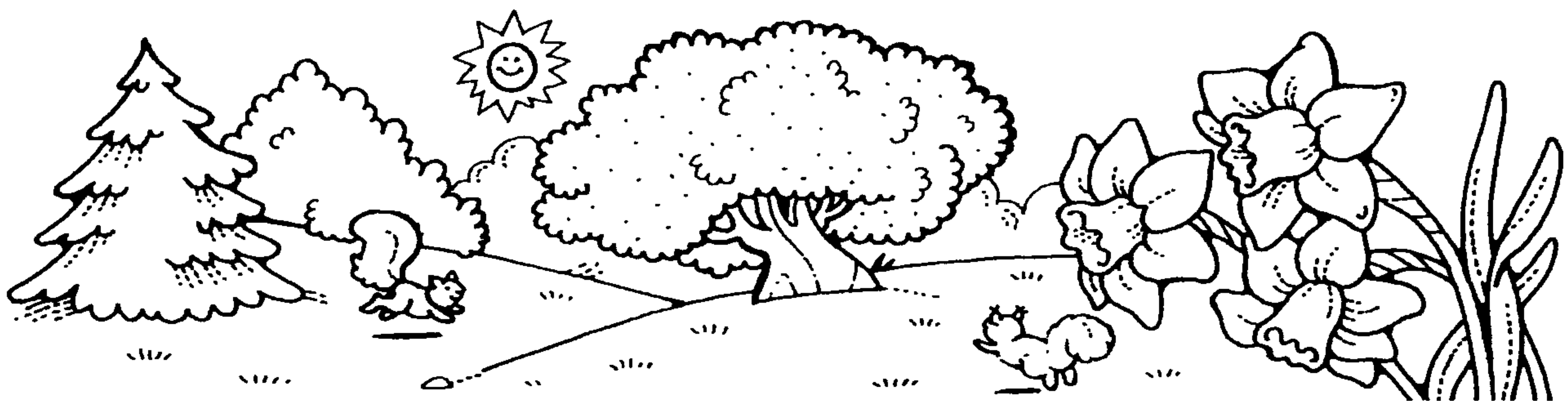

Color the name of the month blue.
Color May fifth green.
Color the names of the days of the week red.

Name: _____

can

Write the sight word on the lines.



I Can Hop



I can hop like a frog.

I _____ swim like a fish.



I _____ look at a star.



I _____ make a wish!

I _____ hop like a bunny.

I _____ creep and leap.



I _____ go to bed.

I _____ fall asleep.



Good Night!





Name _____



Gather, Record, and Interpret Data

Sunday	Monday	Tuesday	Wednesday	Thursday	Friday	Saturday

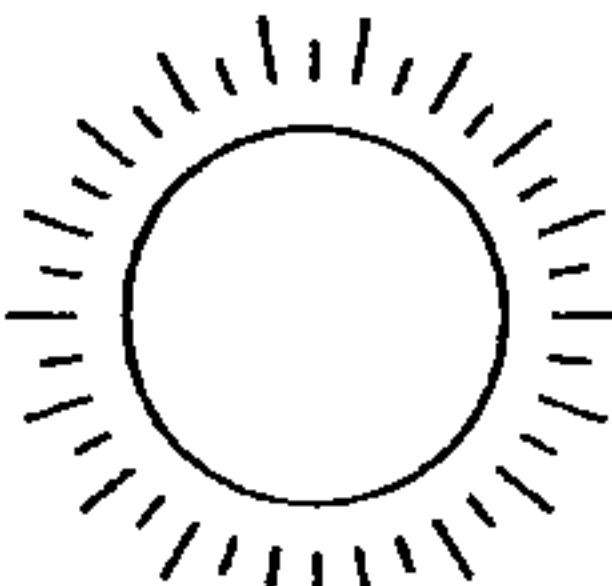

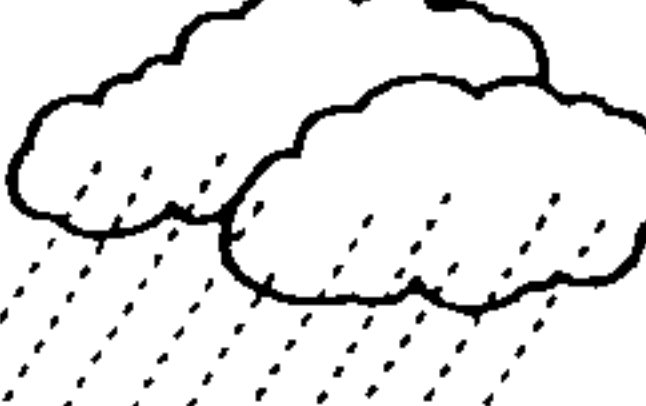
 sunny						
 cloudy						
 rainy						

0 1 2 3 4 5

- Count the number of sunny days in the week. Color one square for each sunny day to show how many there are.
- Count the number of cloudy days in the week. Color one square for each cloudy day to show how many there are.
- Count the number of rainy days in the week. Color one square for each rainy day to show how many there are.

Name _____

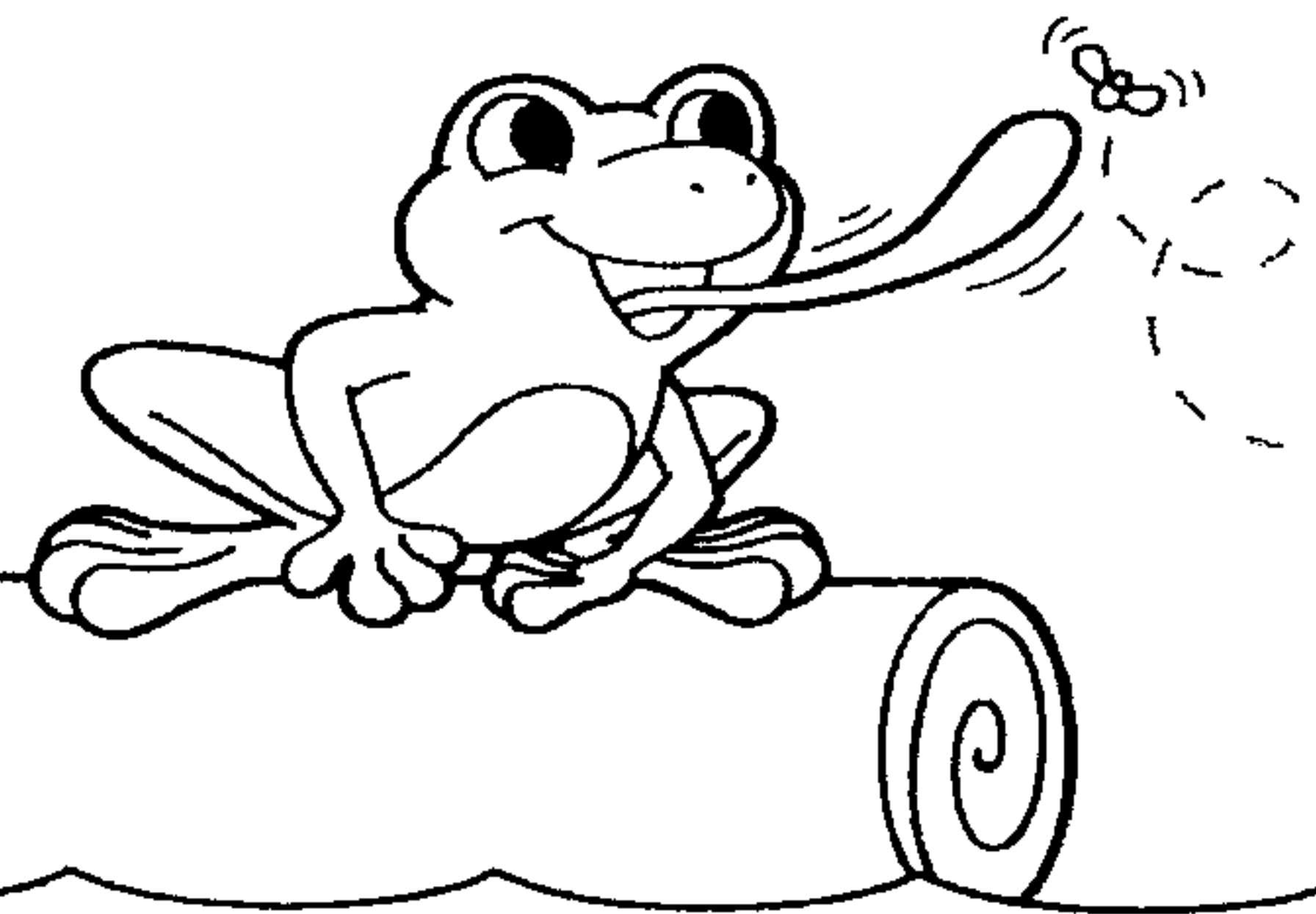
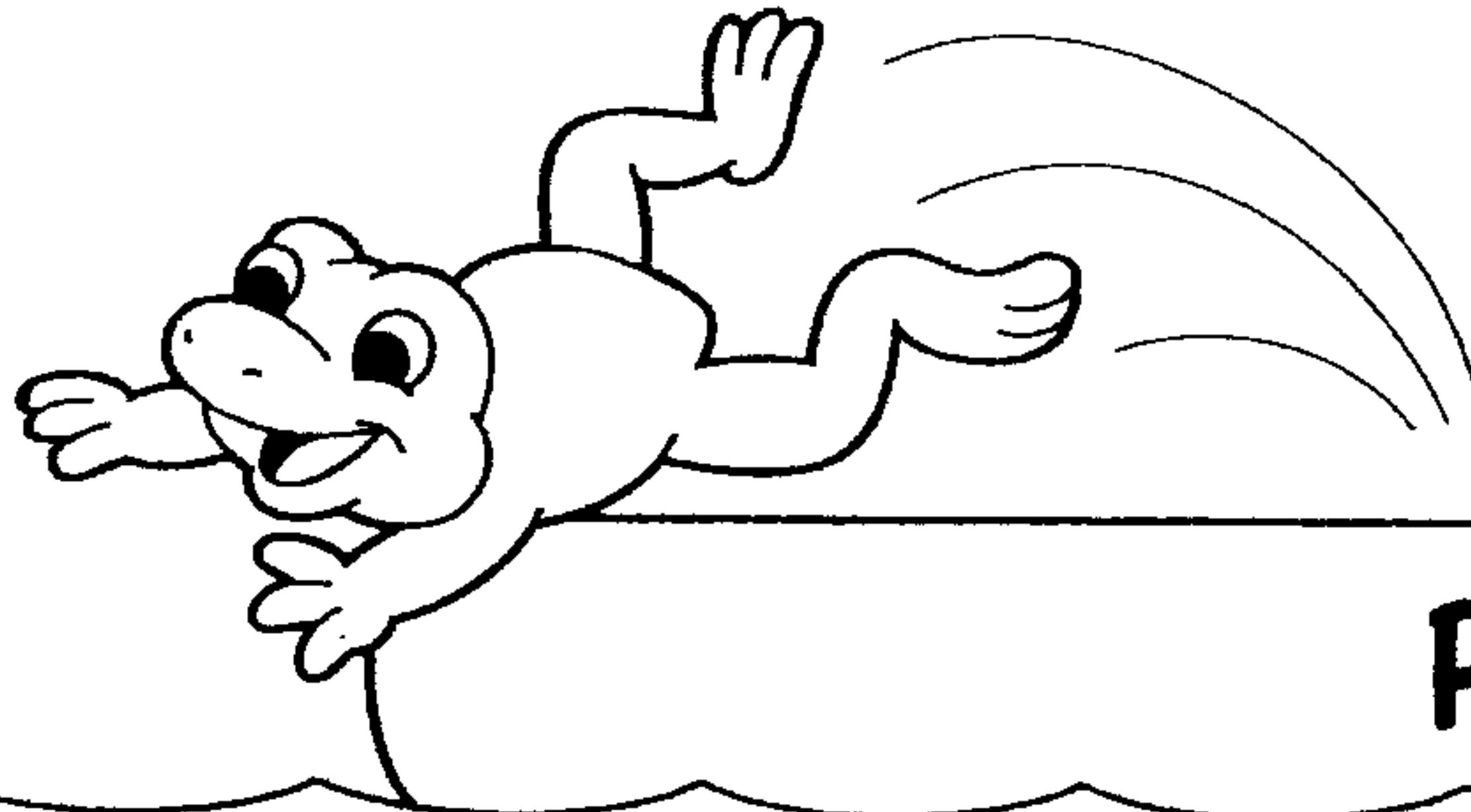

Reading Log

Book title: _____

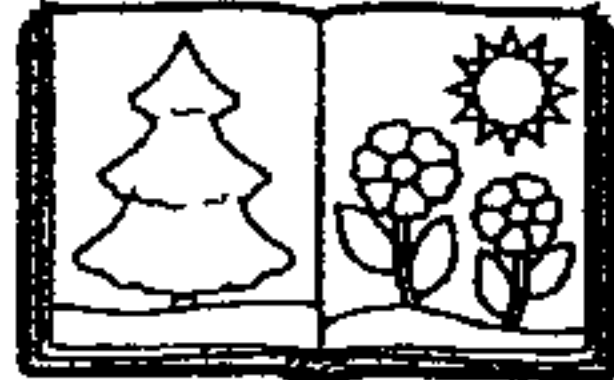

1.



Do you like the **illustrations**?

yes

no

2.

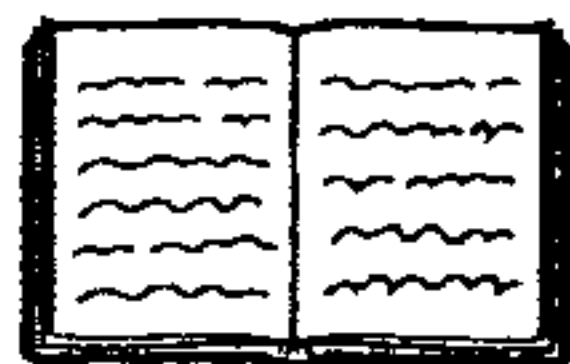

Do you like the **story**?

yes

no

3.

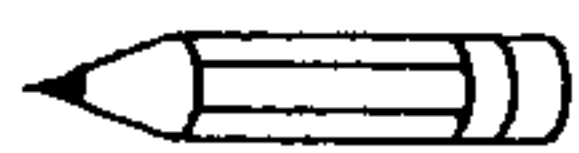

Write.

My favorite part of the story is _____

4.



Draw and color to show your favorite part.

Name _____

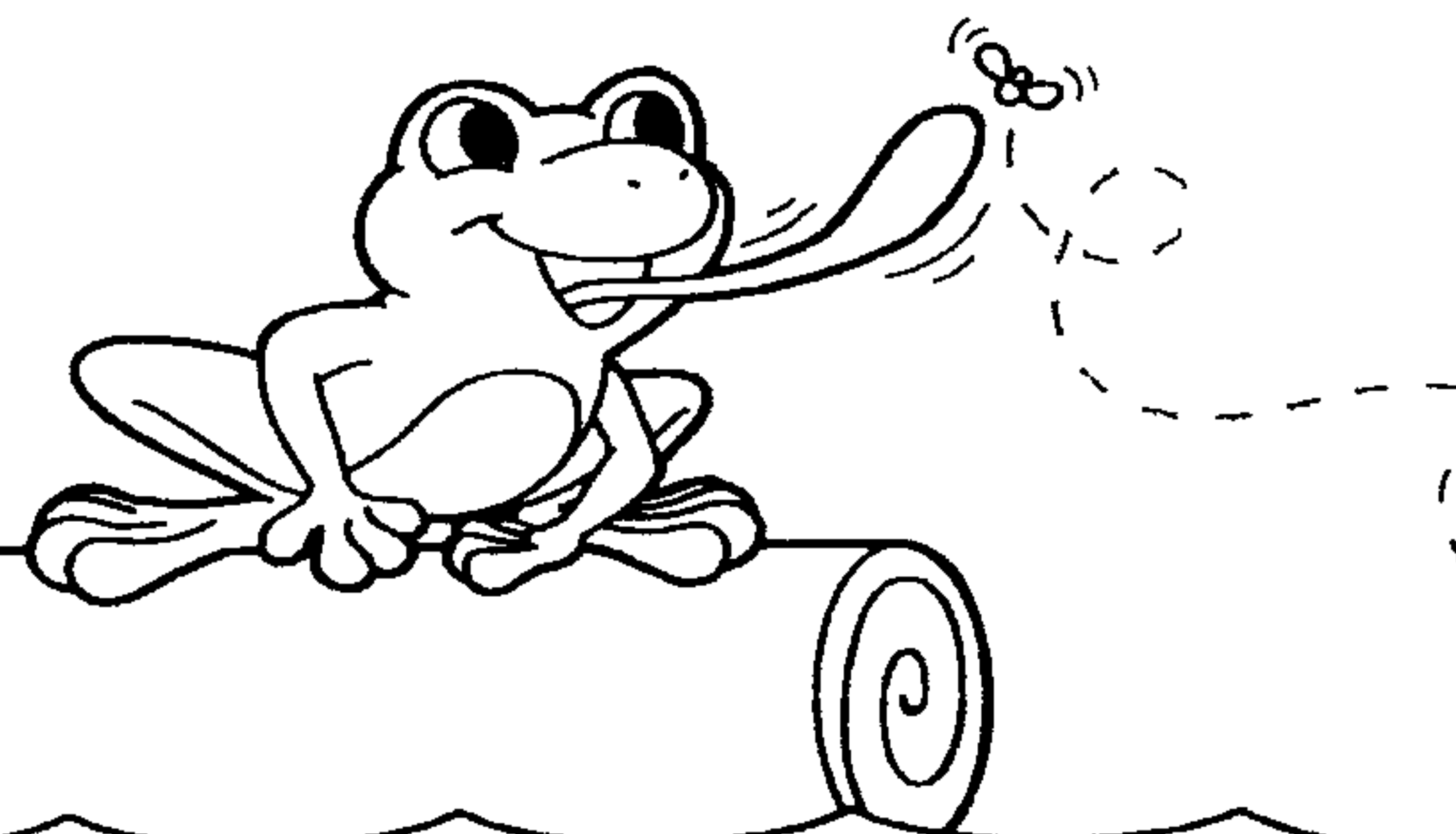
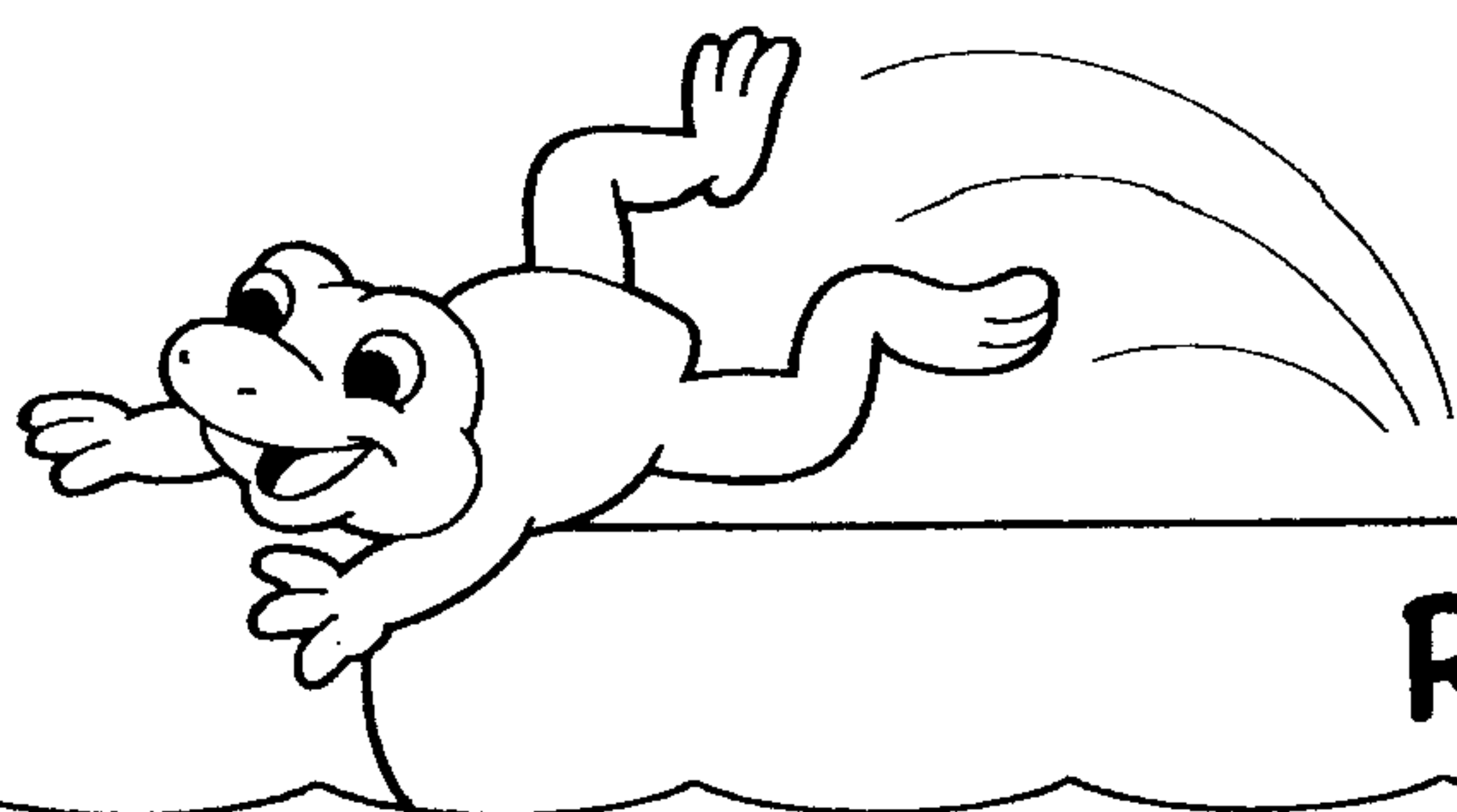

Reading Log

Book title: _____

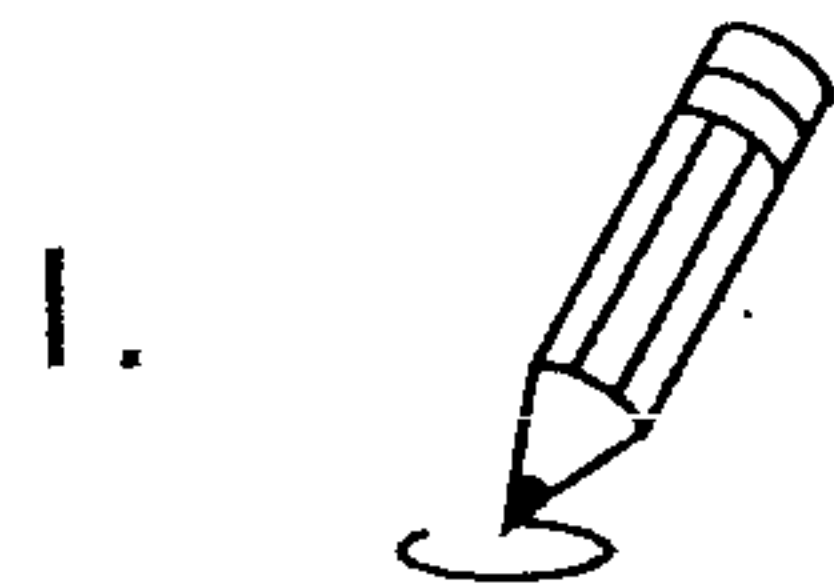
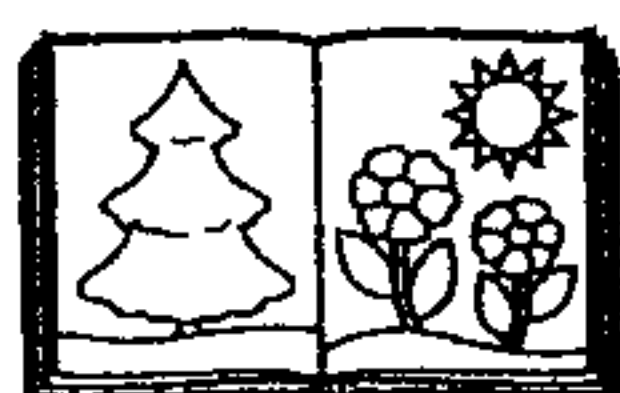

1. Do you like the **illustrations**? yes no

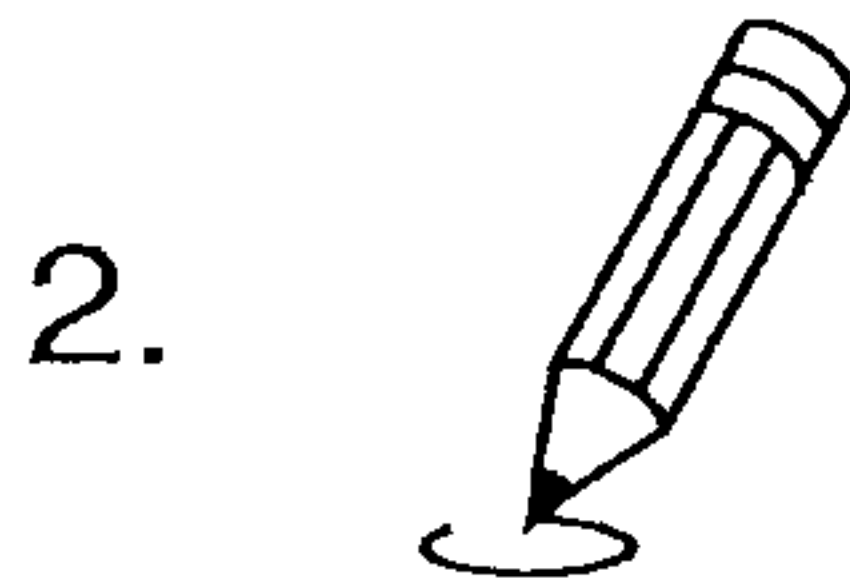
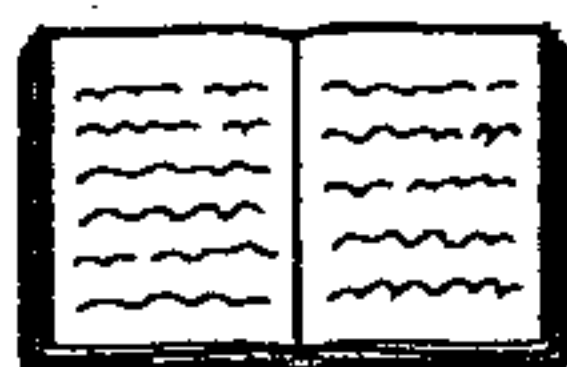

2. Do you like the **story**? yes no

3.  Write.

My favorite part of the story is _____

4.  Draw and color to show your favorite part.

you

Name: _____

Trace the word and say it aloud:

you you you

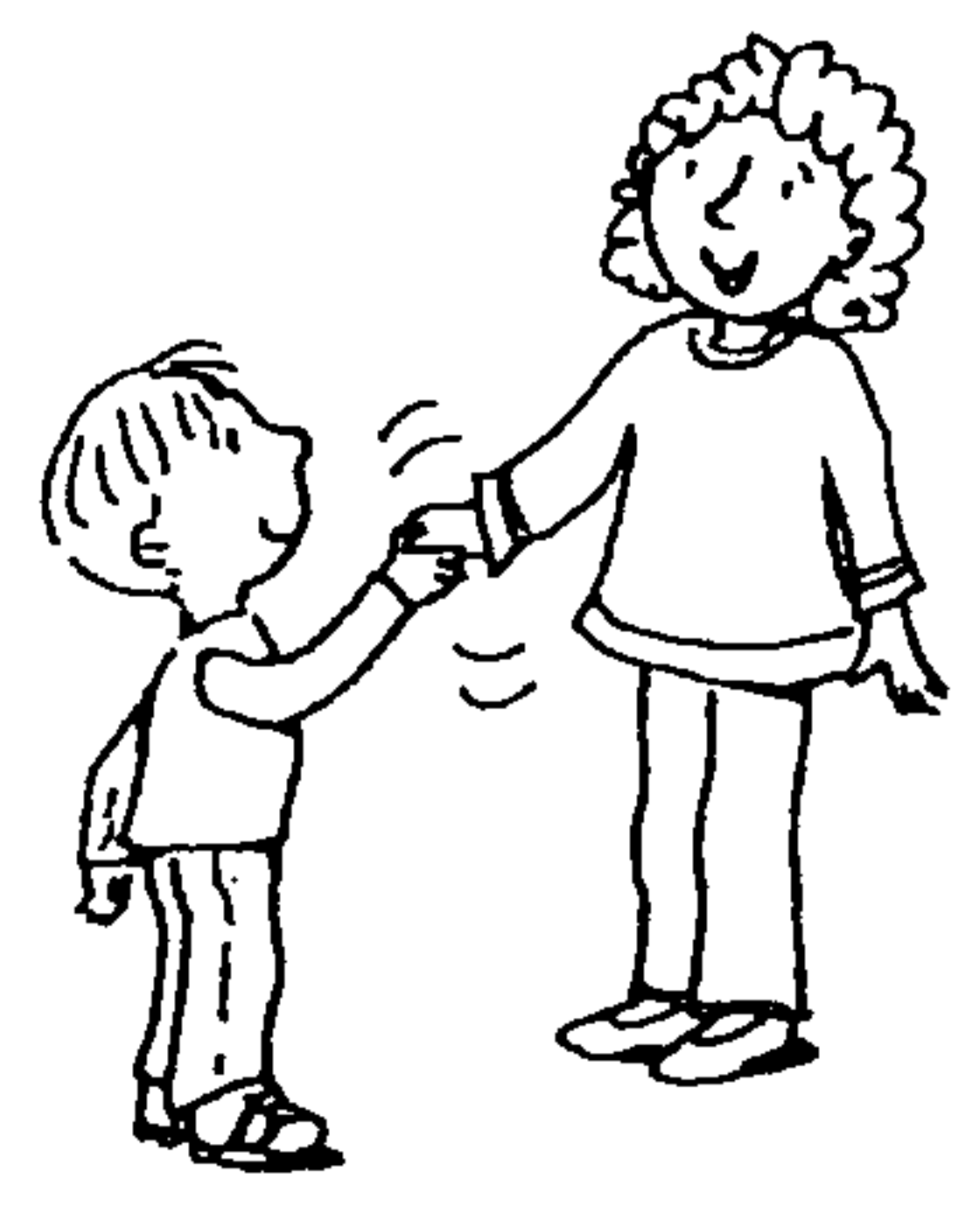

Hello, how are **you**?

Write the word:

Blank handwriting lines for writing the word 'you'.

Cut out the letters at the bottom of the page and mix them up. Then paste them in the right squares to finish the sentence:

Hello, how are ?

Write the word to finish the sentence:

Hello, how are _____?

Write your own sentence using the word:

Blank handwriting lines for writing a sentence.

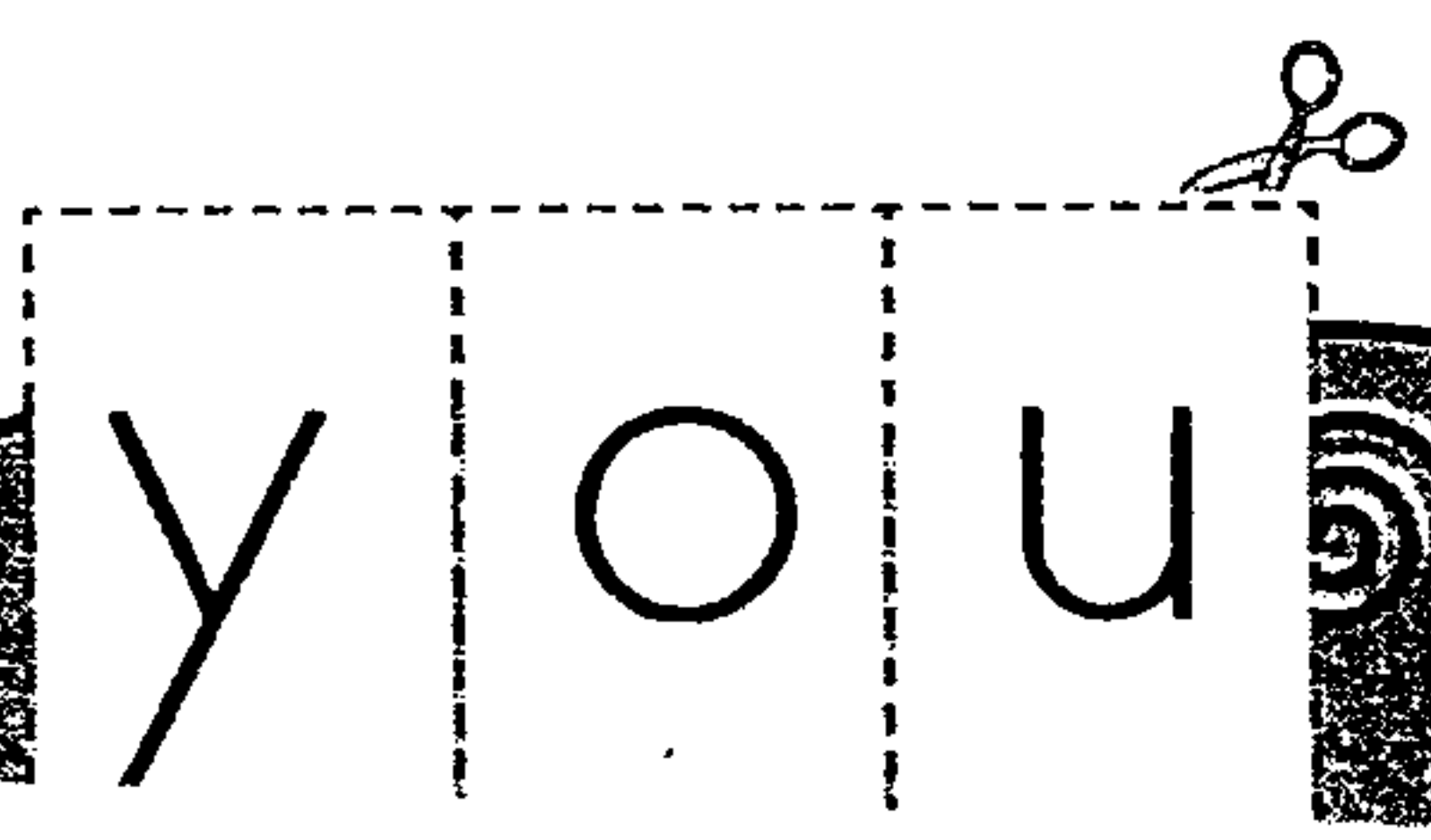

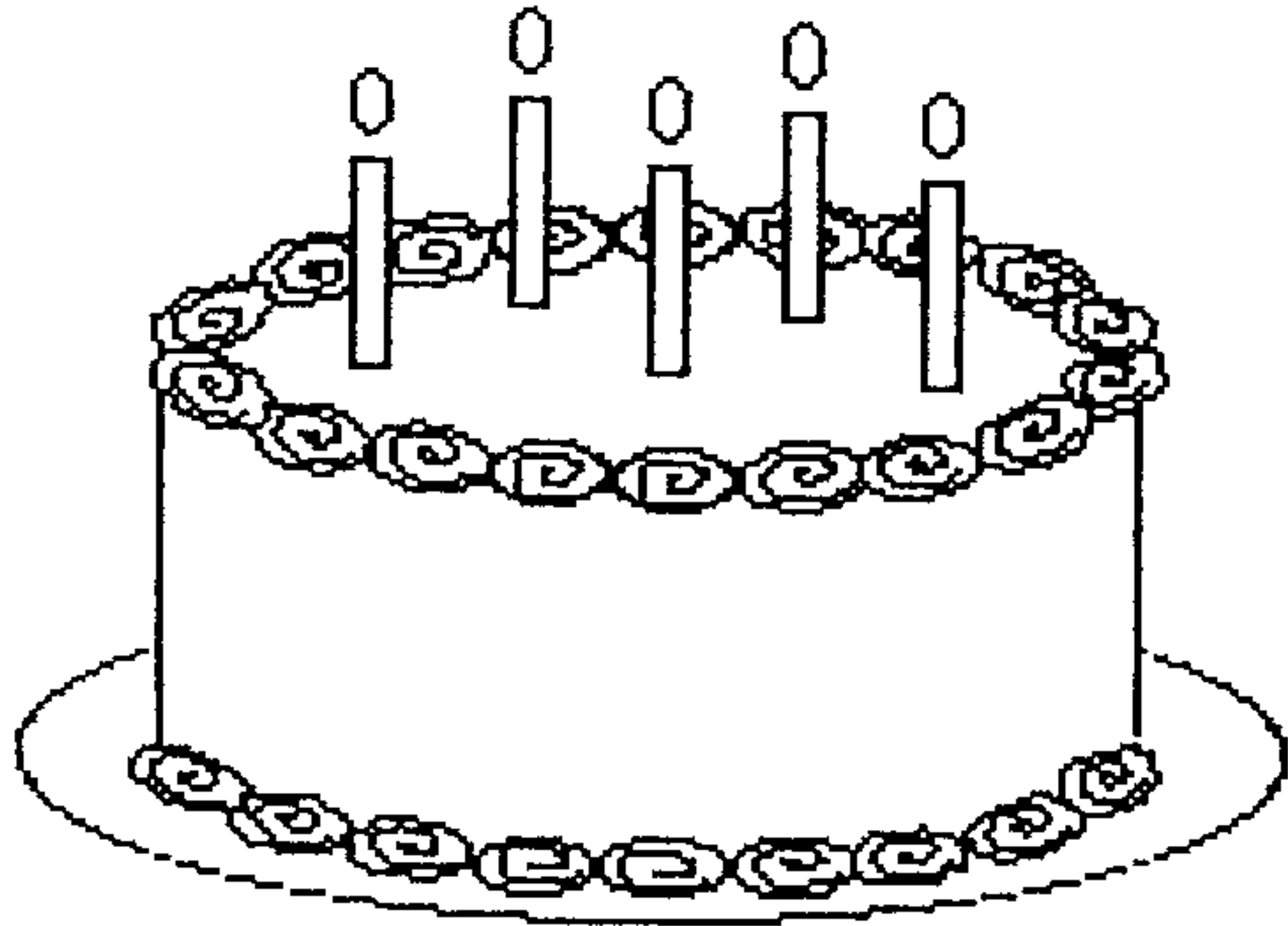

All
About
Me

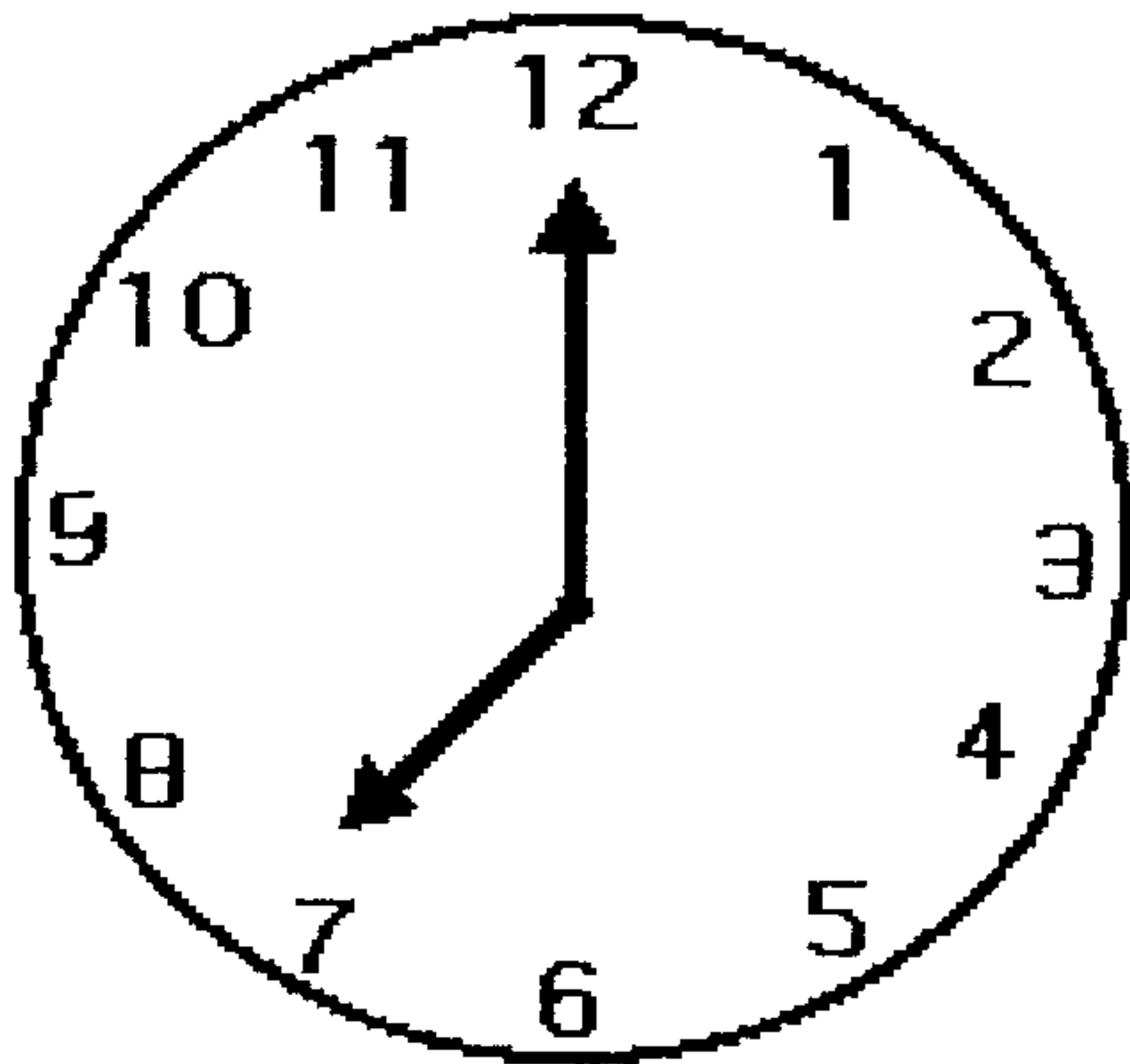
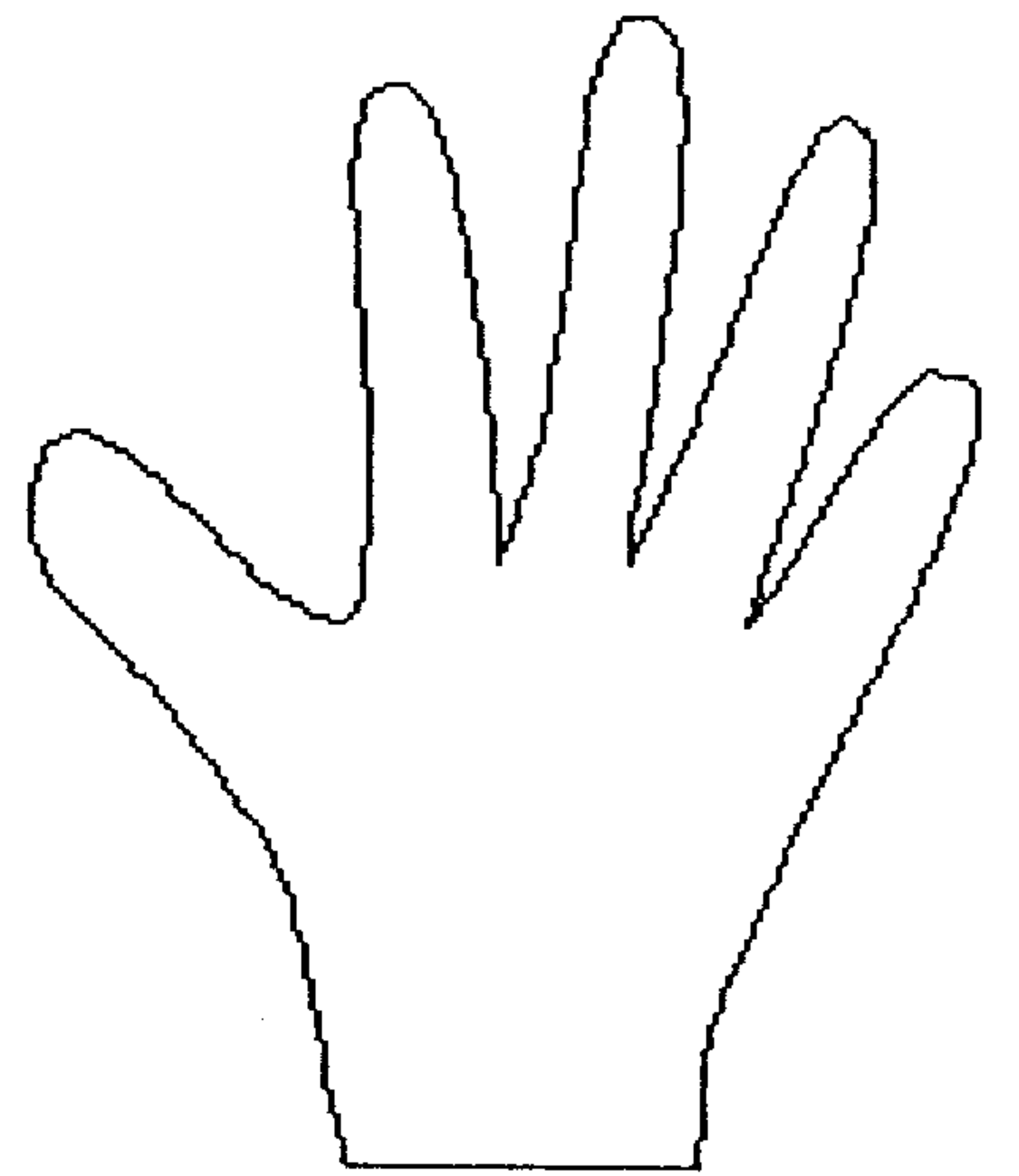

By _____

Put candles on the birthday cake.

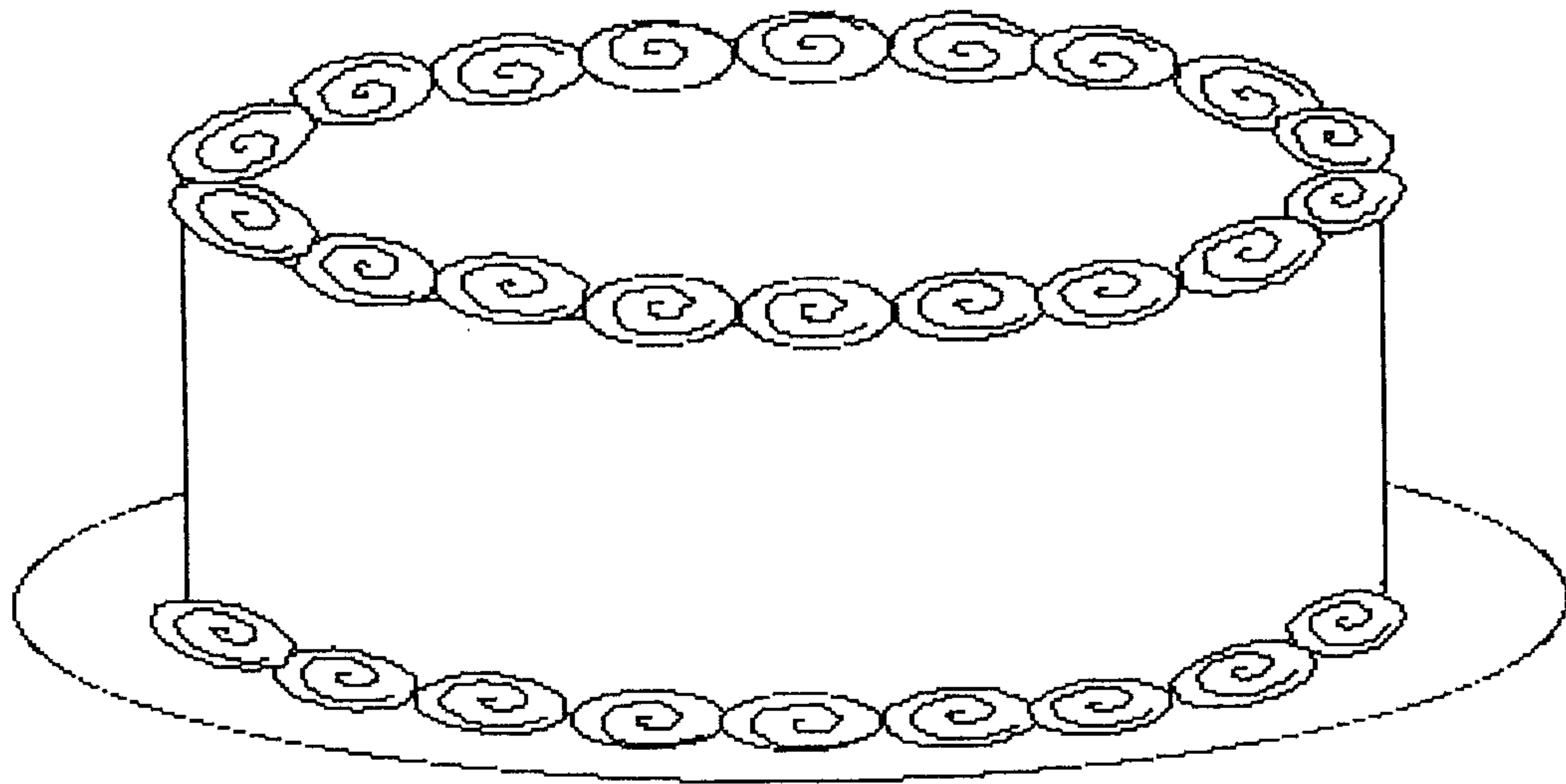

I am _____ years old.

January

July

February

August

March

September

April

October

May

November

June

December

My birthday is in _____.

I can trace my hand.

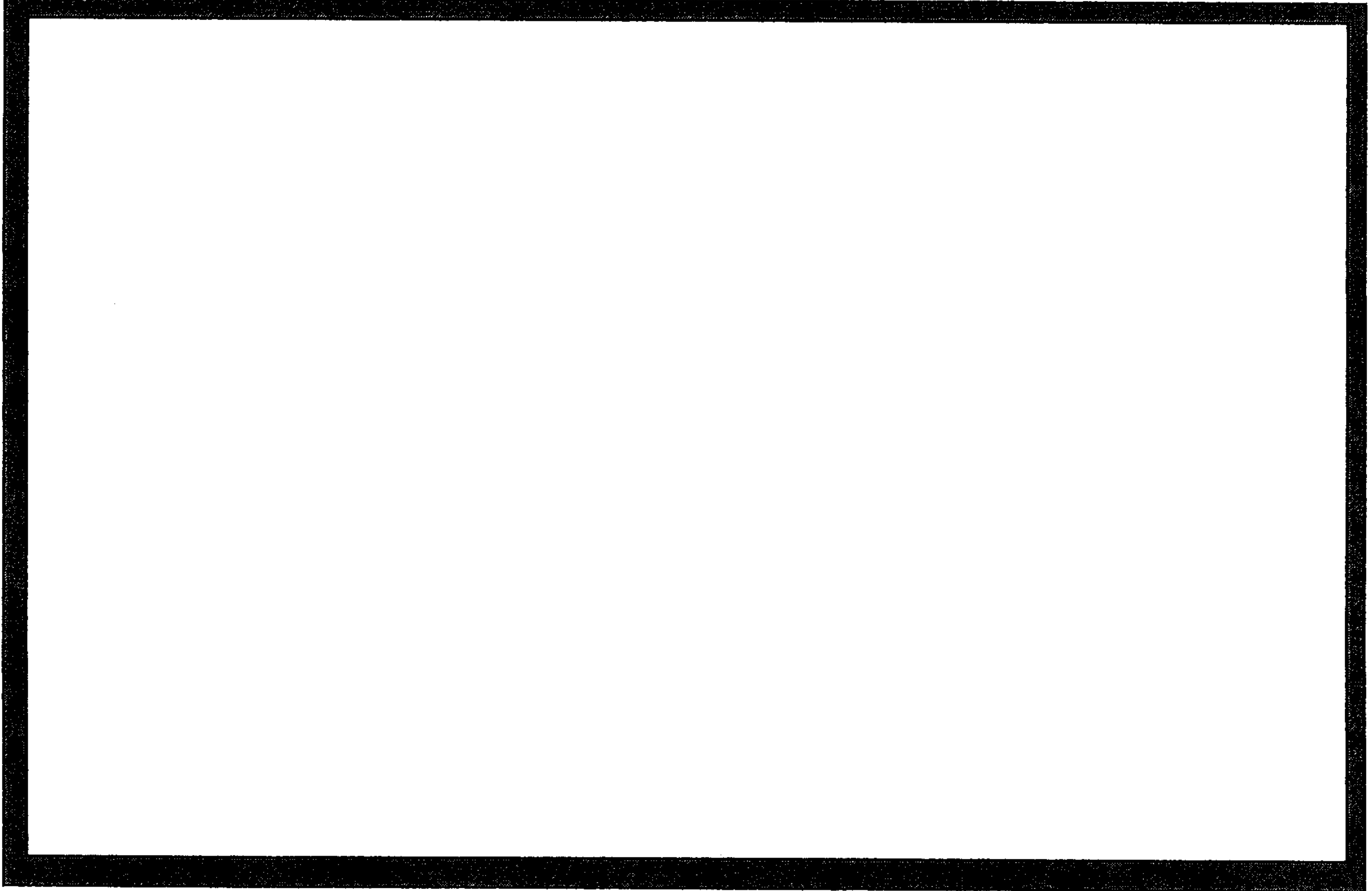

This is my family.

Draw your favorite food.

My favorite food is _____.

Draw your favorite toy.

My favorite toy is _____.

Draw your favorite animal.

My favorite animal is the _____.

Draw something using your favorite color.

My favorite color is _____.

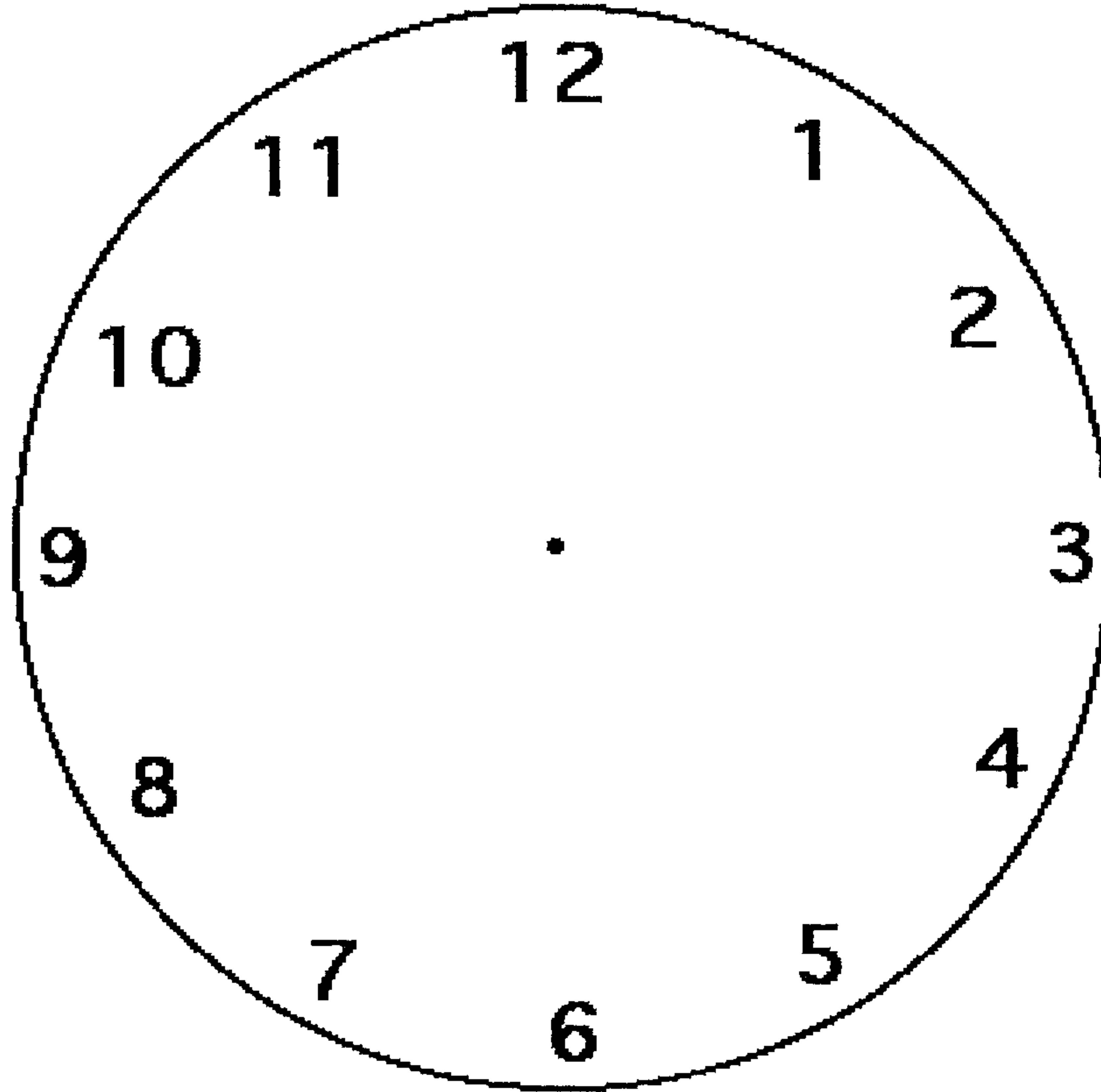

I wake up at _____:_____.

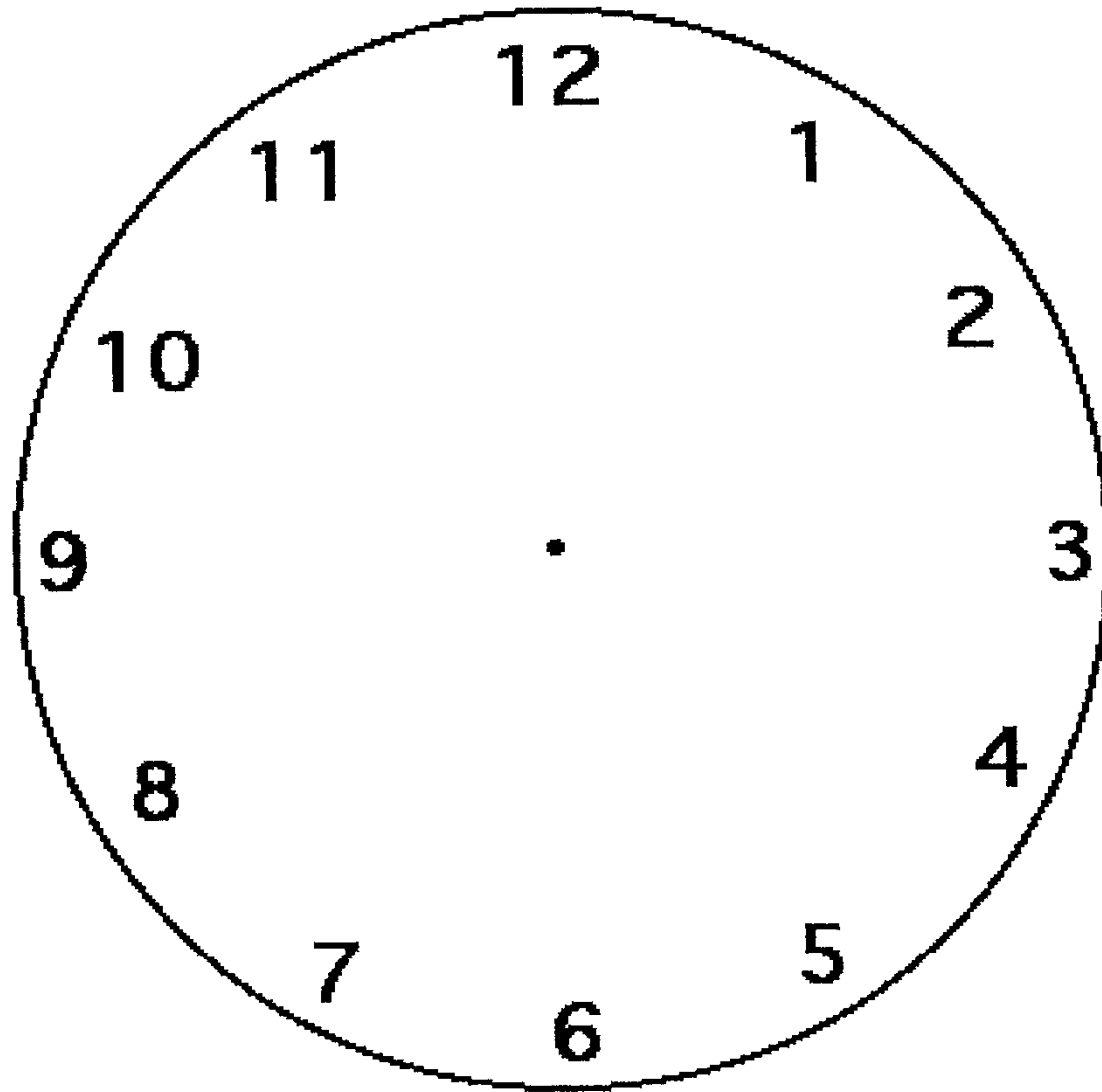

I go to sleep at ____:____.

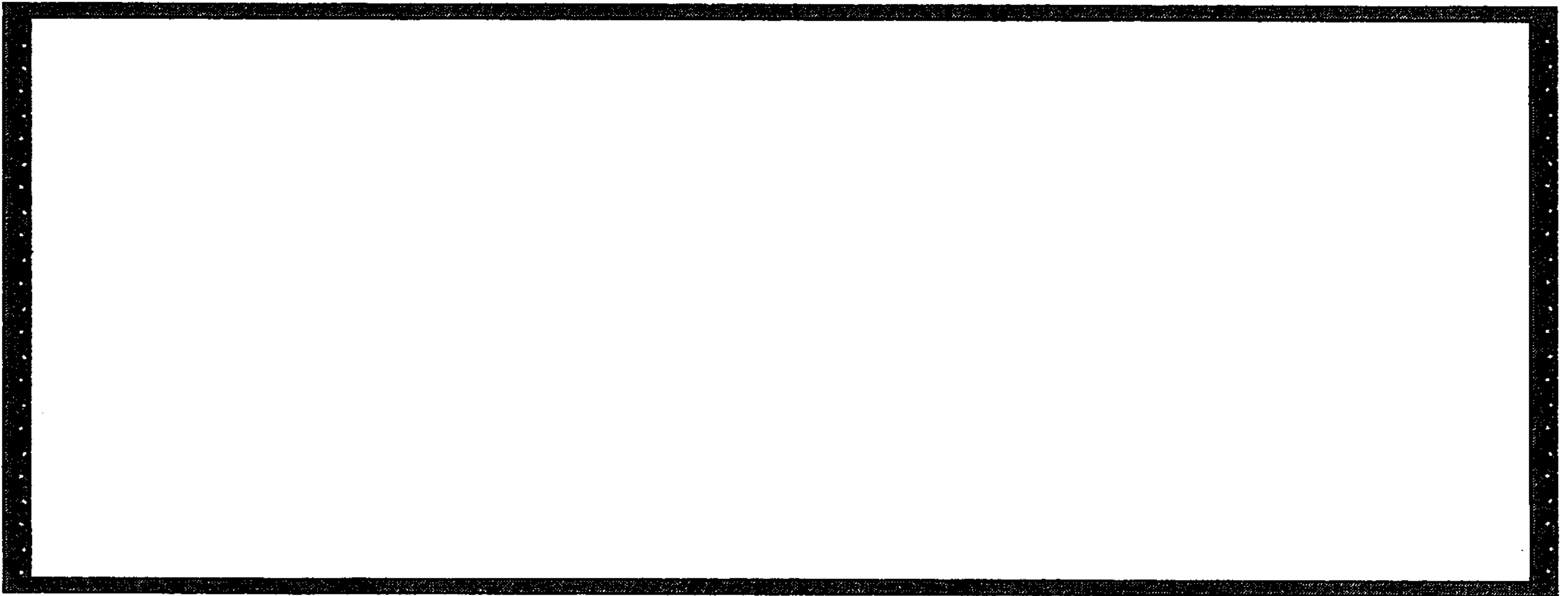

This is where I live.

My address is:

Handwriting practice lines consisting of two sets of three horizontal lines each. Each set includes a solid top line, a dashed middle line, and a solid bottom line.

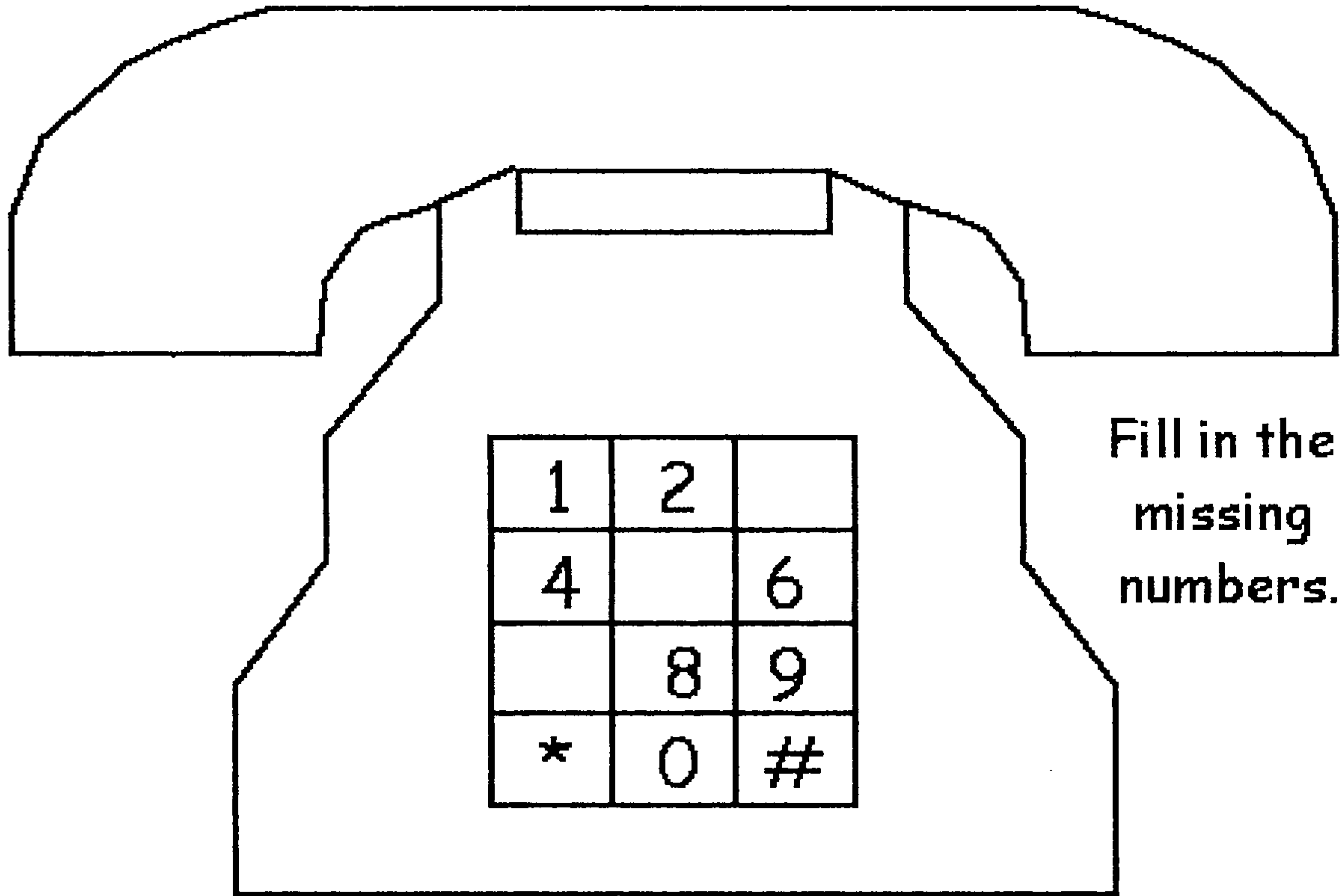

My phone number is:

My Weather Book

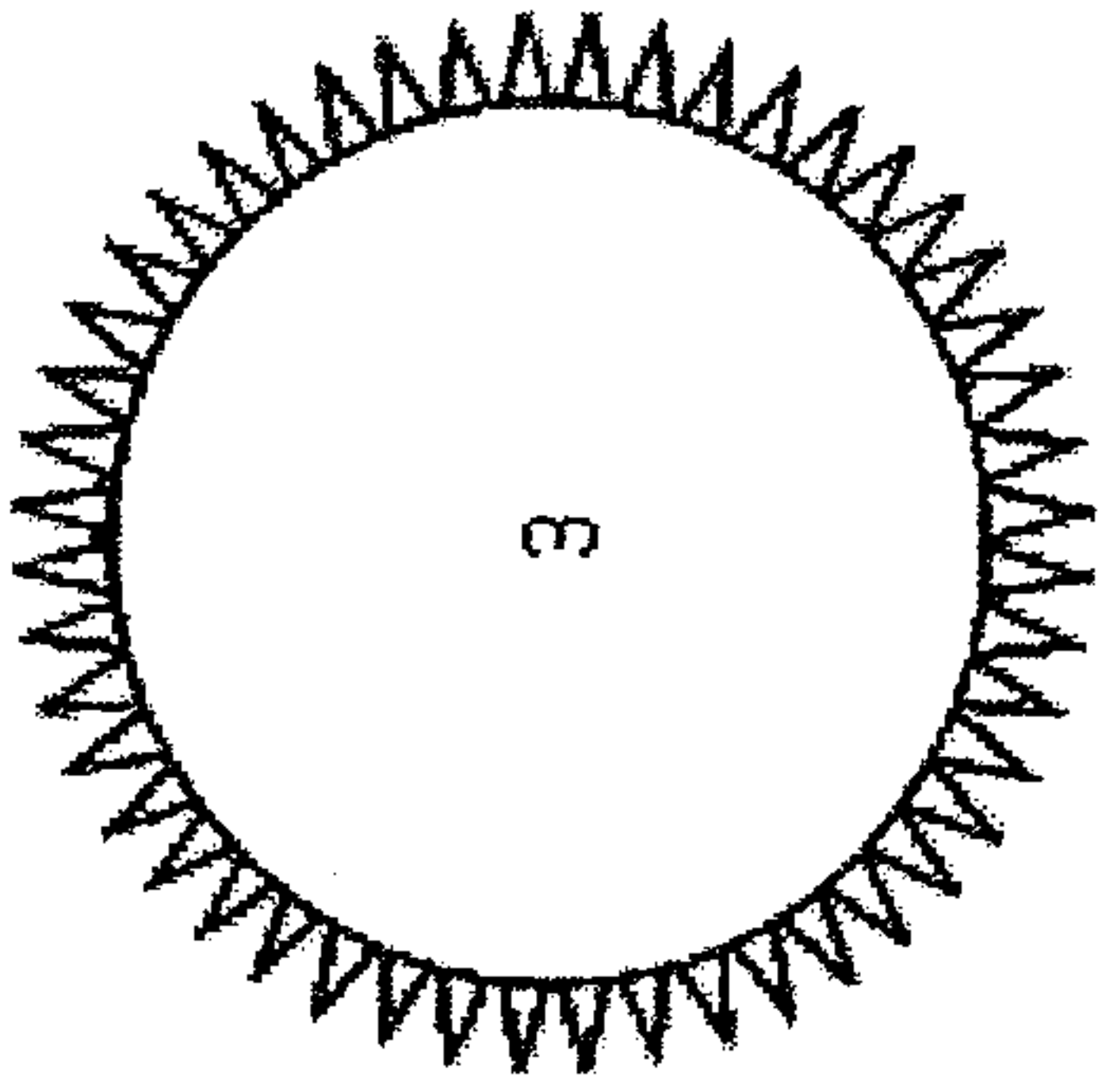

- 1- white
- 2- light blue
- 3- yellow
- 4- red
- 5- orange
- 6- dark blue
- 7- green

2

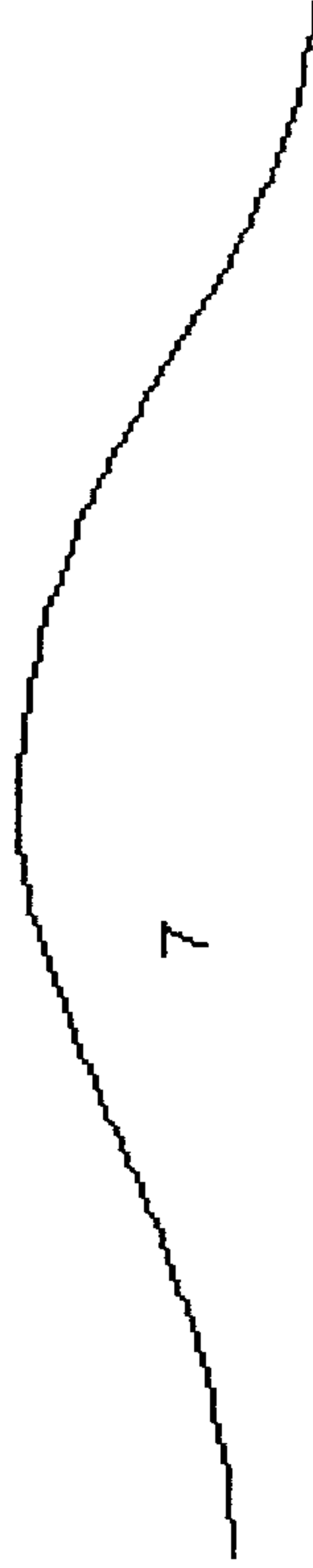

It is sunny.

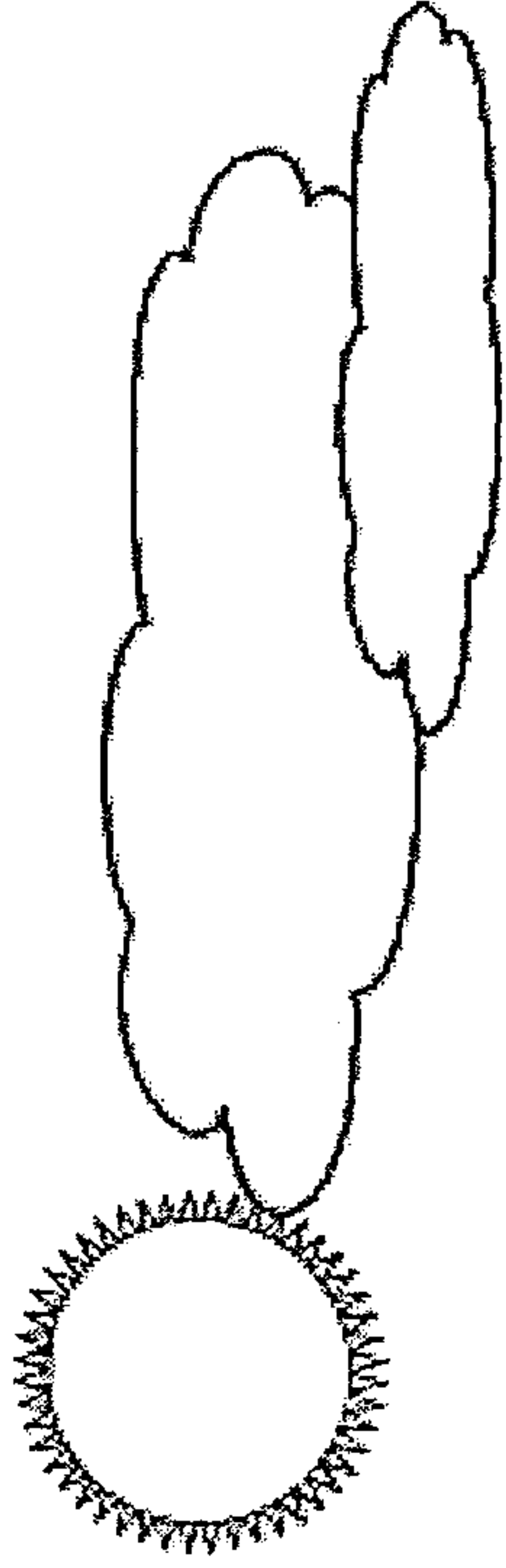

Weather Color-by-Number Book

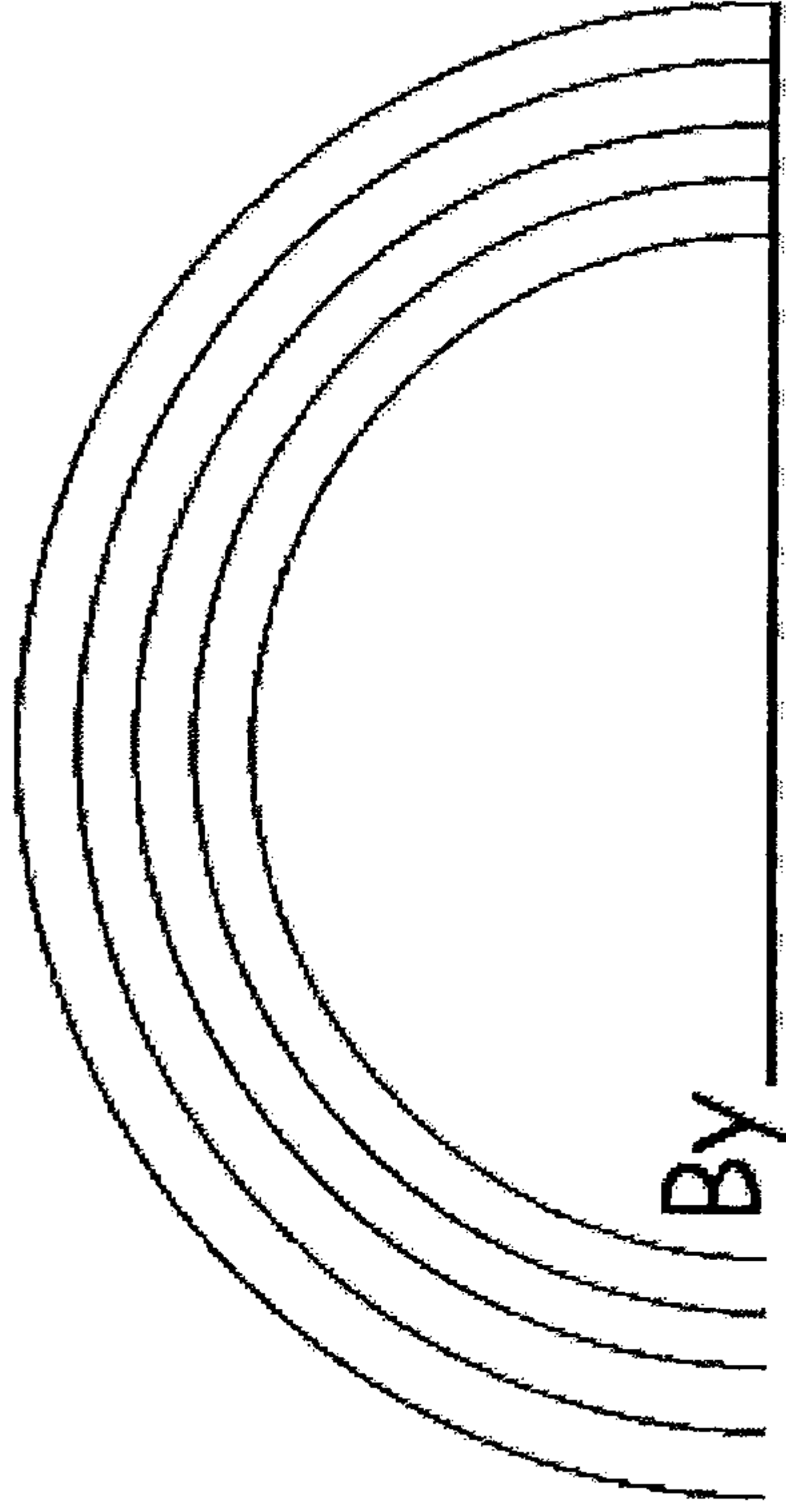

My Weather Book

- 1-white
- 2-light blue

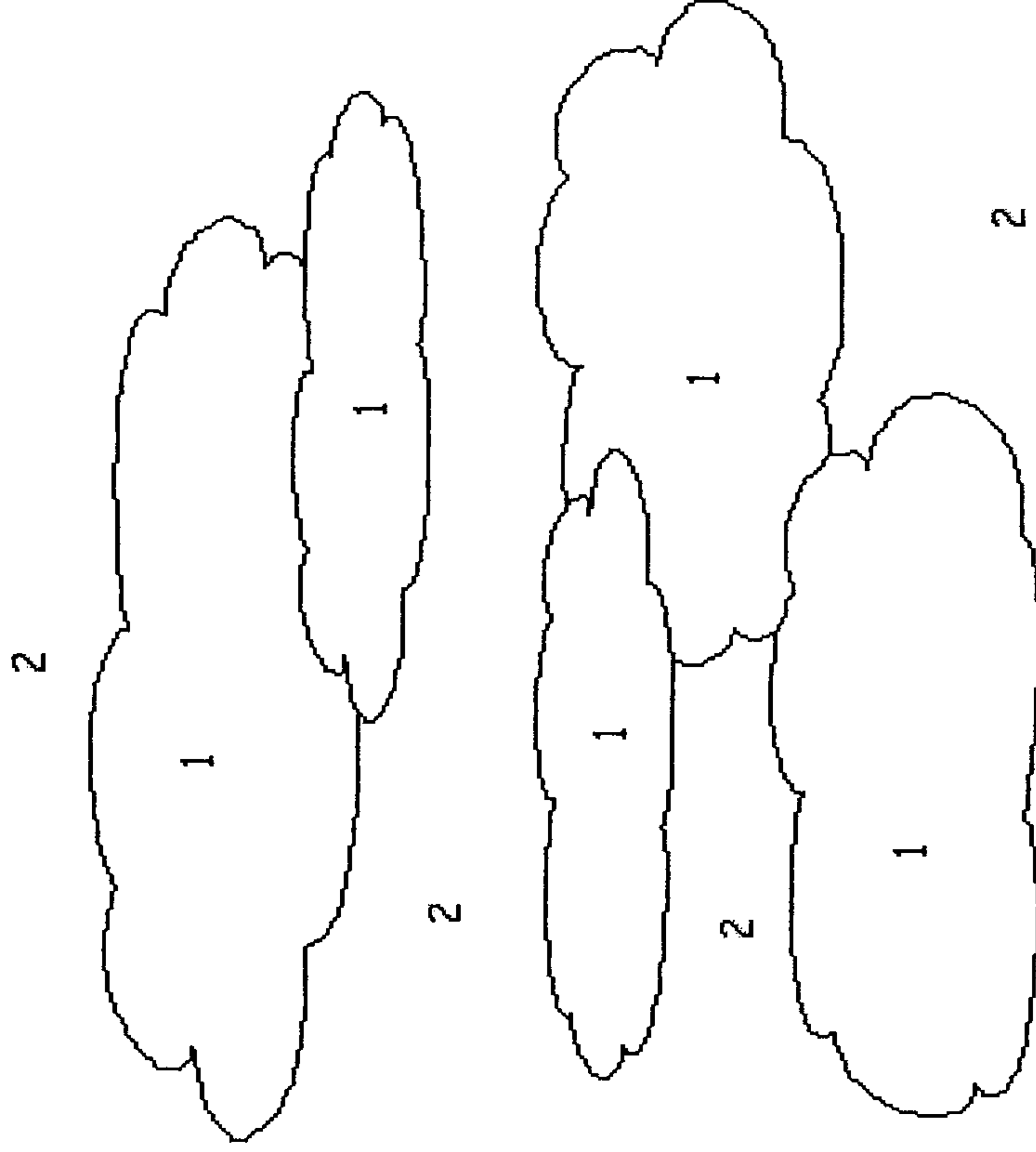

It is cloudy.

My Weather Book

- 1-white
- 2-light blue
- 3-yellow
- 4 red
- 5 orange
- 6-dark blue
- 7-green
- 8-gray

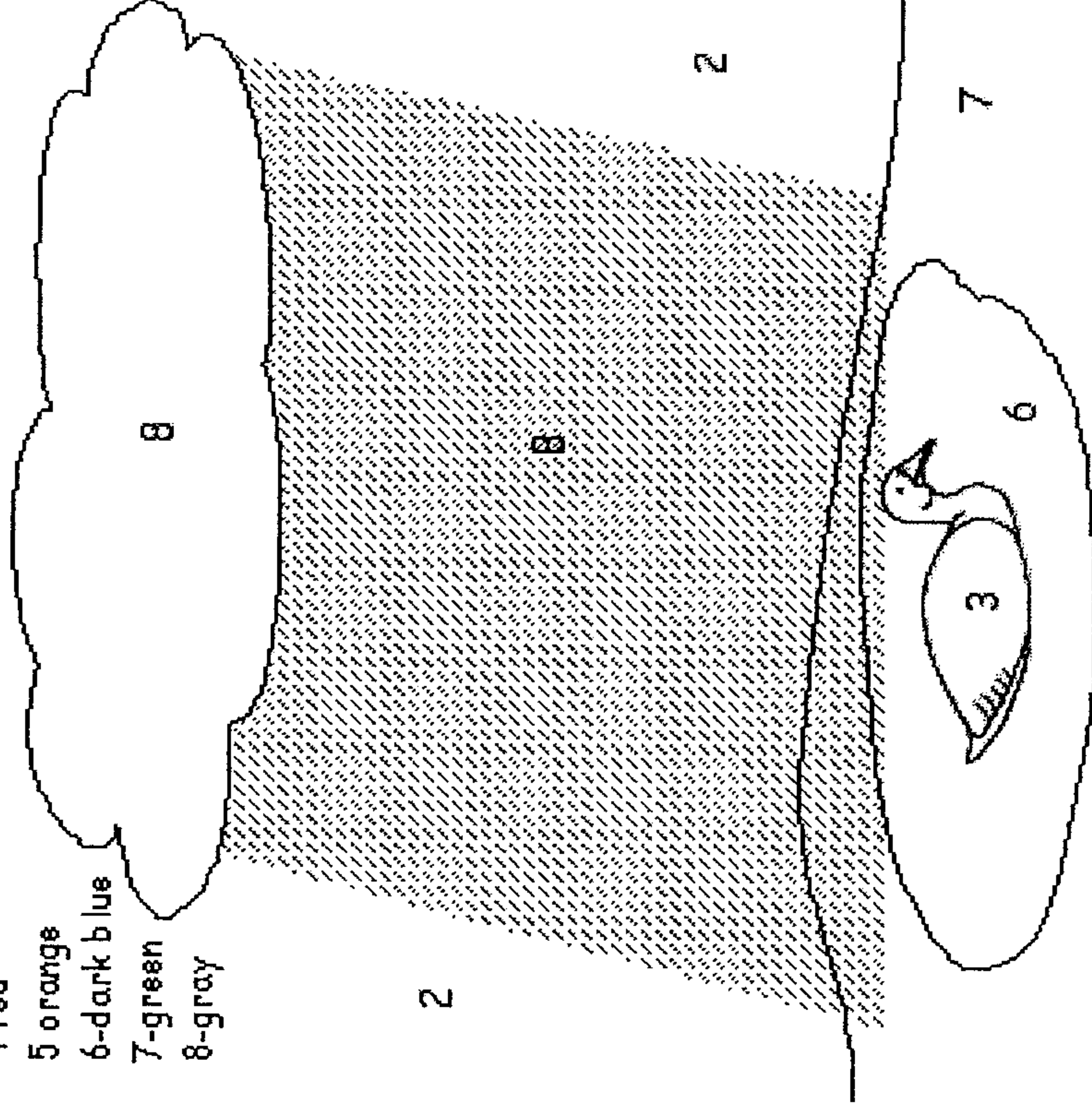

It is raining.

My Weather Book

- 1-white
- 2-light blue
- 3-yellow
- 4 red
- 5 orange
- 6-dark blue
- 7-green
- 8-gray

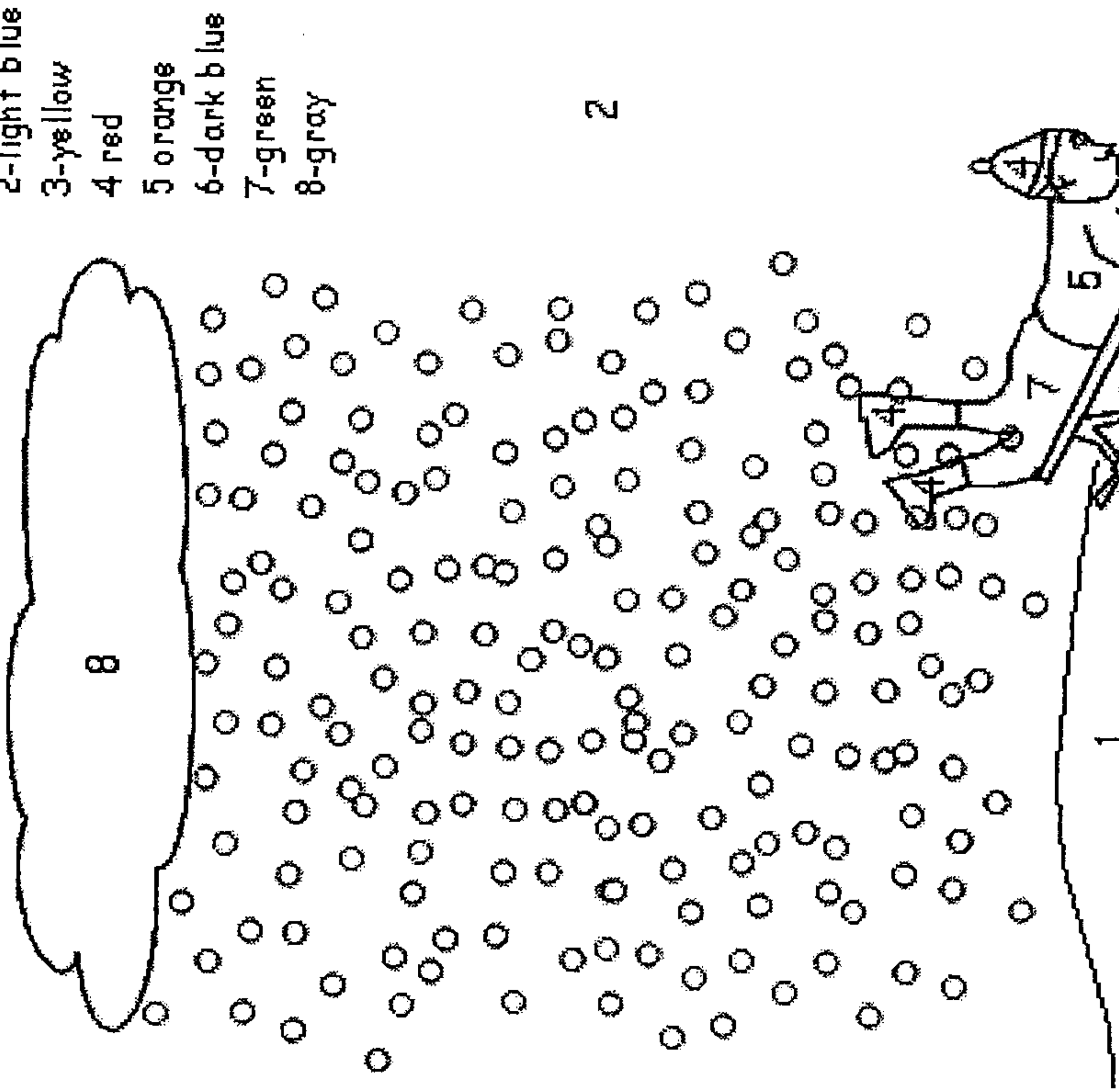

It is snowing.

My Weather Book

- 1-white
- 2-light blue
- 3-yellow
- 4 red
- 5 orange
- 6-dark blue
- 7-green
- 8-gray

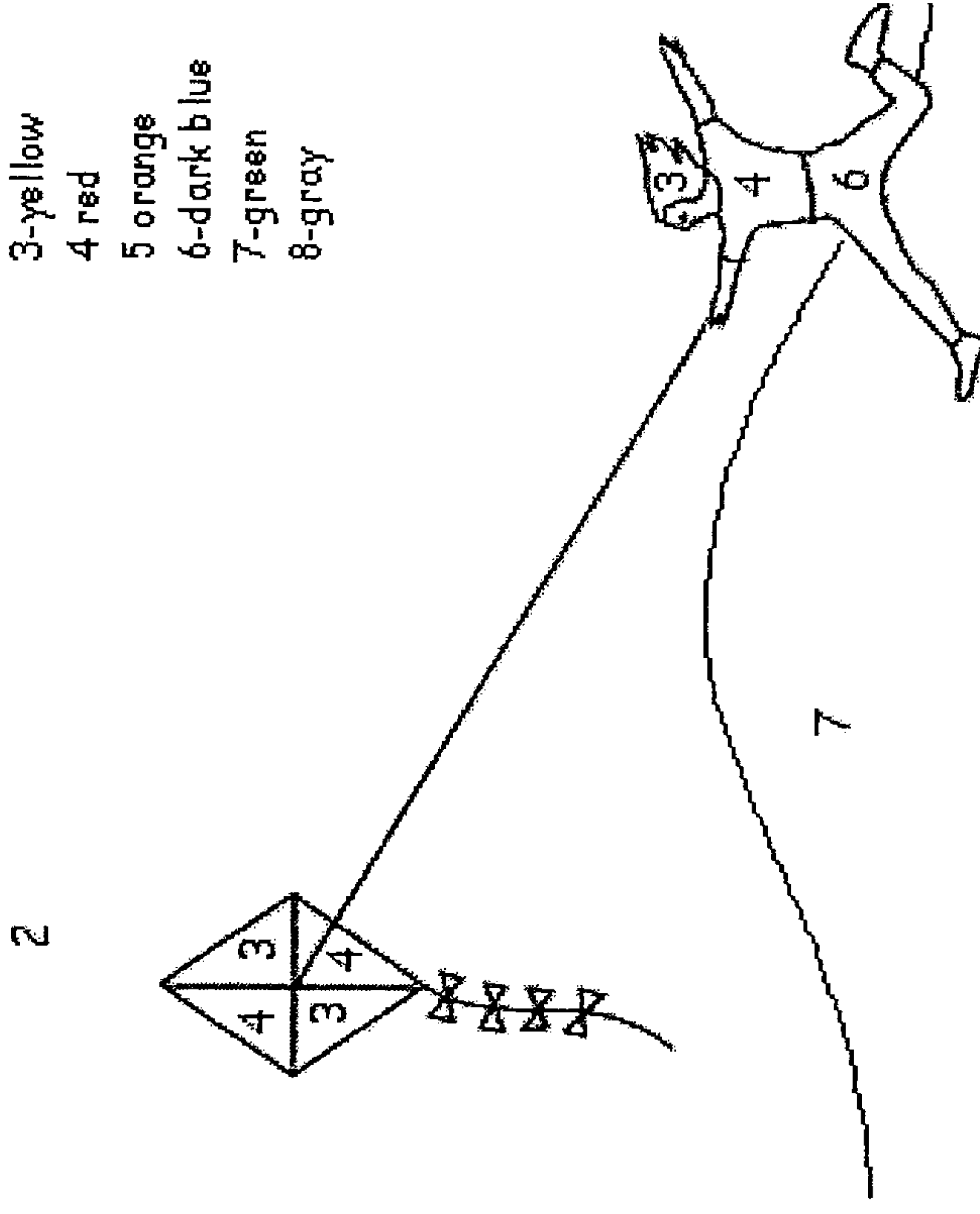

It is windy.

My Weather Book

1-white

1

It is foggy.

©EnchantedLearning.com

My Weather Book

- 1-white
- 2-light blue
- 3-yellow
- 4 red
- 5 orange
- 6-dark blue
- 7-green
- 8-gray

2

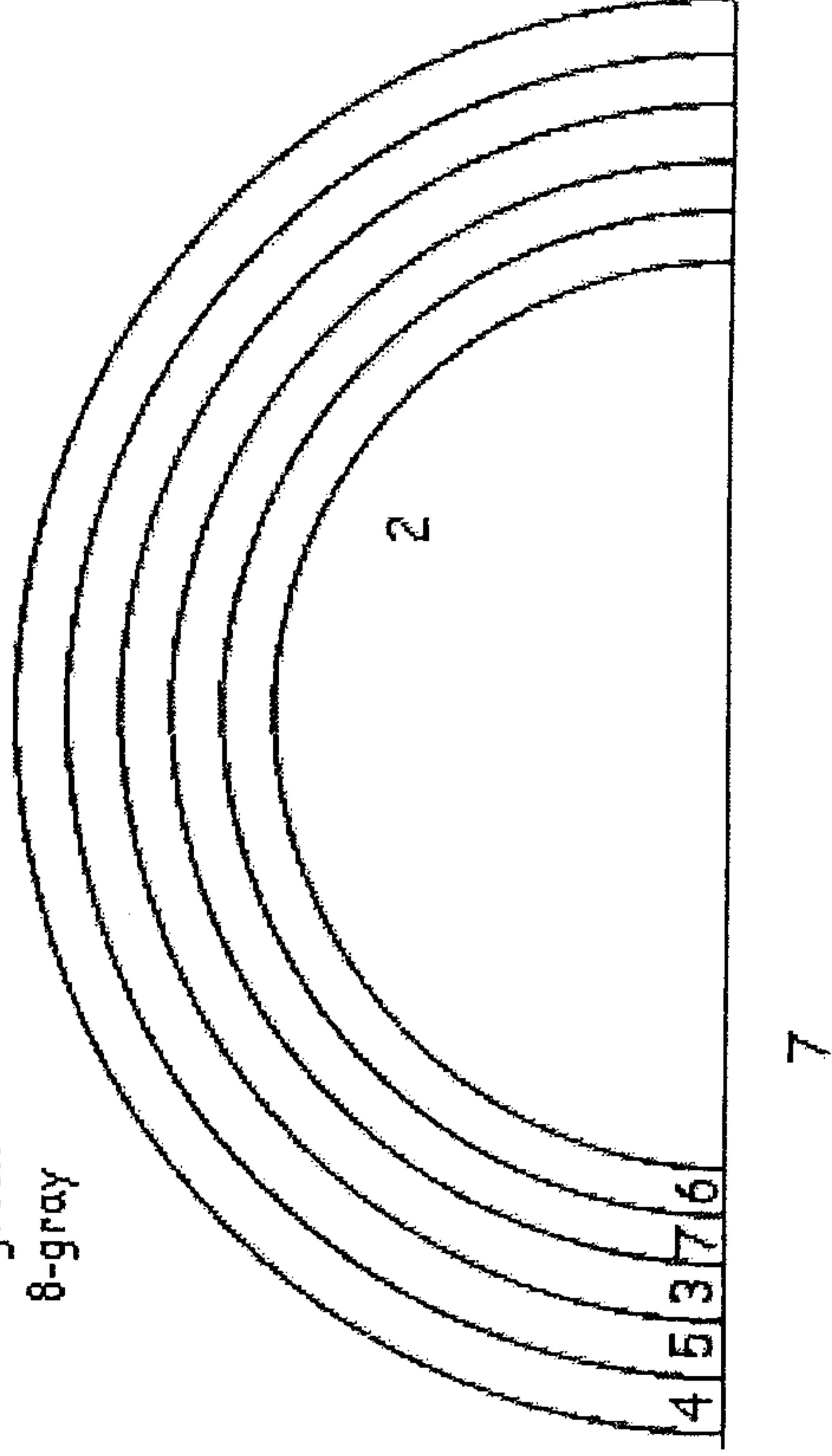

7

I see a rainbow!

©EnchantedLearning.com